

ASSP VOLTAGE DETECTOR

MB3761

VOLTAGE DETECTOR

Designed for voltage detector applications, the Fujitsu MB3761 is a dual comparator with a built-in high precision reference voltage generator. Outputs are open-collector outputs and enable use of the OR-connection between both channels. Both channels have hysteresis control outputs. Because of a wide power supply voltage range and a low power supply current, the MB3761 is suitable for power supply monitors and battery backup systems.

- Wide power supply voltage range: 2.5 V to 40 V
- Low power and small voltage dependency supply current: 250 μ A typical.
- Built-in stable low voltage generator: 1.20 V typical.
- Easy-to-add hysteresis characteristics.
- Package: 8-pin Plastic SIP Package (Suffix: -PS)
8-pin Plastic DIP Package (Suffix: -P)
8-pin Plastic FPT Package (Suffix: -PF)

ABSOLUTE MAXIMUM RATINGS (See NOTE)

Rating	Symbol	Value	Unit
Power Supply Voltage	V _{CC}	41	V
Output Voltage	V _O	41	V
Output Current	I _O	50	mA
Input Voltage	V _{IN}	-0.3 to +6.5	V
Power Dissipation	P _D	350 (T _A \leq 70°C)	mW
Storage Temperature	T _{STG}	-55 to 125	°C

NOTE: Permanent device damage may occur if **ABSOLUTE MAXIMUM RATINGS** are exceeded. Functional operation should be restricted to the conditions as detailed in the operational sections of this data sheet. Exposure to absolute maximum rating conditions for extended periods may affect device reliability.

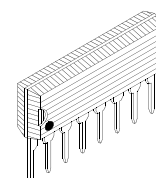

PLASTIC PACKAGE
SIP-08P-M03

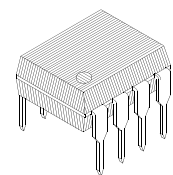

PLASTIC PACKAGE
DIP-08P-M01

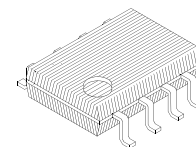

PLASTIC PACKAGE
FPT-08P-M01

PIN ASSIGNMENT

(FRONT VIEW)

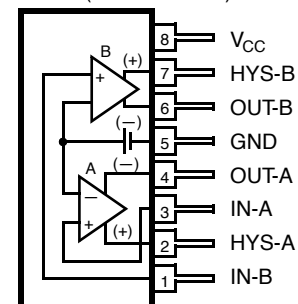

(TOP VIEW)

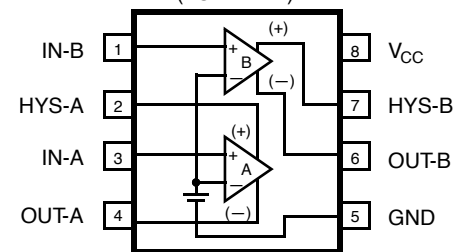

This device contains circuitry to protect the inputs against damage due to high static voltages or electric fields. However, it is advised that normal precautions be taken to avoid application of any voltage higher than maximum rated voltages to this high impedance circuit.

Figure 1. MB3761 Equivalent Circuit

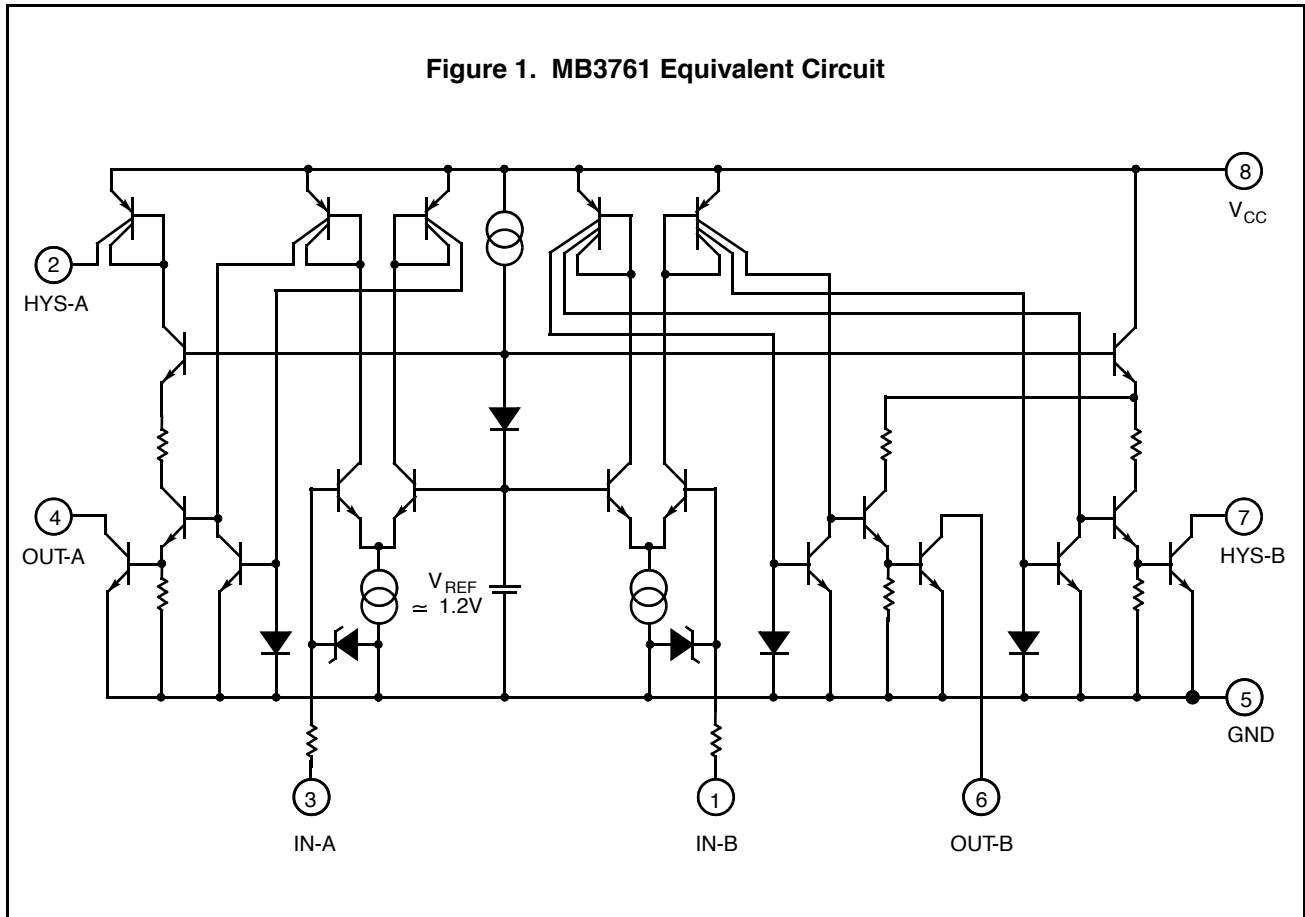

■ RECOMMENDED OPERATING CONDITIONS

Parameter	Symbol	Value	Unit
Power Supply Voltage	VCC	2.5 to 40	V
Operating Temperature	TA	-20 to 75	°C
Output Current at pin 4	IO4	4.5	mA
Output Current at pin 6	IO6	3.0	mA

■ ELECTRICAL CHARACTERISTICS

TA=25°C, VCC=5V

Parameter	Designator	Conditions	Values			Unit
			Min	Typ	Max	
Power Supply Voltage	ICCL	VCC=40 V, VIL=1.0 V	-	250	400	μA
	ICCH	VCC=40 V, VIH=1.5 V	-	400	600	μA
Threshold Voltage	VTH	IO =2 mA, VO=1 V	1.15	1.20	1.25	V
Deviation of Threshold Voltage	ΔVTH1	2.5 V ≤ VCC ≤ 5.5 V	-	3	12	mV
	ΔVTH2	4.5 V ≤ VCC ≤ 40 V	-	10	40	mV
Offset Voltage between Outputs	VOOSA	IOA= 4.5 mA, VOA=2 V IHA= 20 mA, VHA=3 V	-	2.0	-	mV
	VOSSB	IOB=3 mA, VOB=2 V IHB=3 mA, VHB=2 V	-	2.0	-	mV
Temperature Coefficient of Threshold Voltage	α	-20°C ≤ TA ≤ 70°C	-	±0.05	-	mV/°C
Difference Voltage on Threshold Voltage between Channel	ΔVTHAB		-10	-	-10	mV
Input Current	IIL	VIL=1.0 V	-	5		nA
	IIH	VIH=1.5 V	-	100	500	nA
Output Leakage Current	IOH	VO=40 V, VIL=1.0 V	-	-	1	μA
Hysteresis Output Leakage Current	IHLA	VCC=40 V, VHA=0 V, VIL=1.0 V	-	-	0.1	μA
	IHHB	VHB=40 V, VIH=1.5 V	-	-	1	μA
Output Sink Current	IOLA	VO=1.0 V, VIH=1.5 V	6	12	-	mA
	IOLB	VO=1.0 V, VIH=1.5 V	4	10	-	mA
Hysteresis Current	IHHA	VH=0 V, VIH=1.5 V	40	80	-	μA
	IHLB	VH=1.0 V, VIL=1.0 V	4	10	-	mA
Output Saturation Voltage	VOLA	IO= 4.5 mA, VIH=1.5 V	-	120	400	mV
	VOLB	IO= 3.0 mA, VIH=1.5 V	-	120	400	mV
Hysteresis Saturation	VHHA	IH= 20 μA, VIH=1.5 V	-	50	200	mV
	VHLB	IH= 3.0 mA, VIL=1.0 V	-	120	400	mV
Output Delay Time	tPHL	RL=5 KΩ	-	2	-	μs
	tPLH	RL=5 KΩ	-	3	-	μs

Figure 2. Operational Definitions

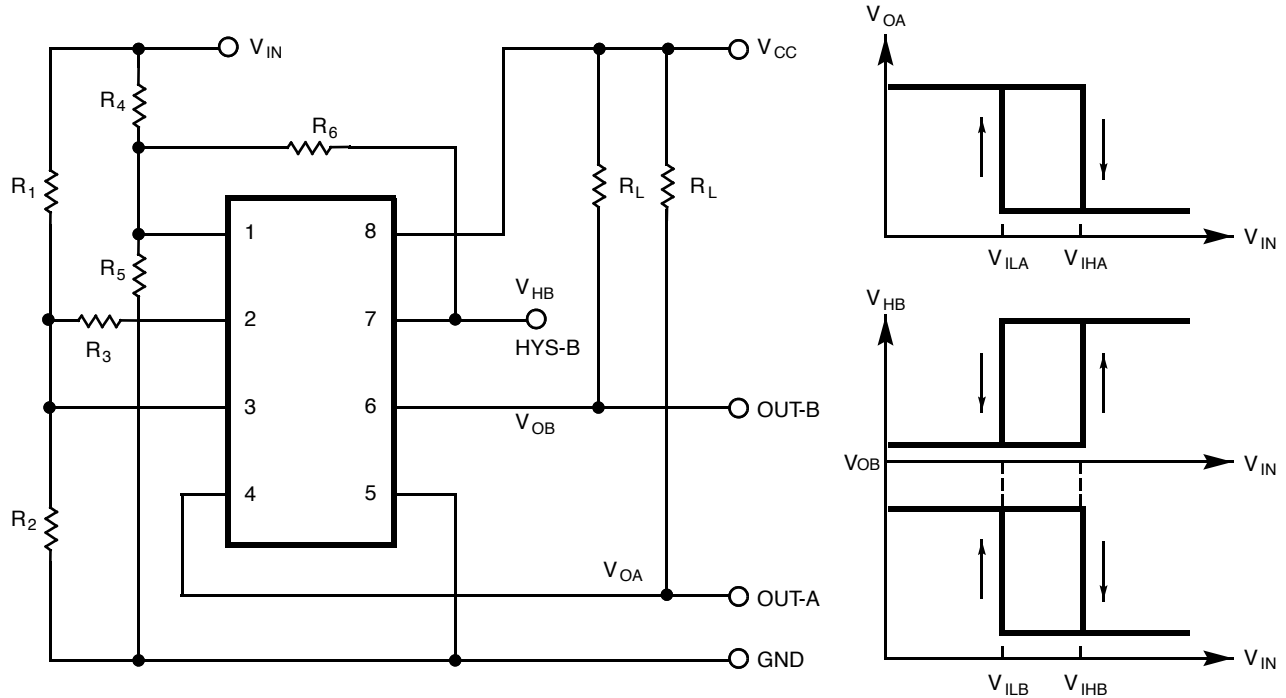

$$V_{IHA} = \left(1 + \frac{R_1}{R_2}\right) V_R$$

$$V_{ILA} = \left(1 + \frac{R_1}{R_2 // R_3}\right) V_R - \frac{R_1}{R_3} V_{CC}$$

$$V_{IHB} = \left(1 + \frac{R_4}{R_5 // R_6}\right) V_R$$

$$V_{ILB} = \left(1 + \frac{R_4}{R_5}\right) V_R$$

NOTE)

$$V_R \approx V_{TH} (\approx 1.20V)$$

$$R_2 // R_3 = \frac{R_2 R_3}{R_2 + R_3}$$

$$R_5 // R_6 = \frac{R_5 R_6}{R_5 + R_6}$$

■ TYPICAL PERFORMANCE CHARACTERISTICS

Fig. 3 - Power Supply Current vs Power Supply Voltage

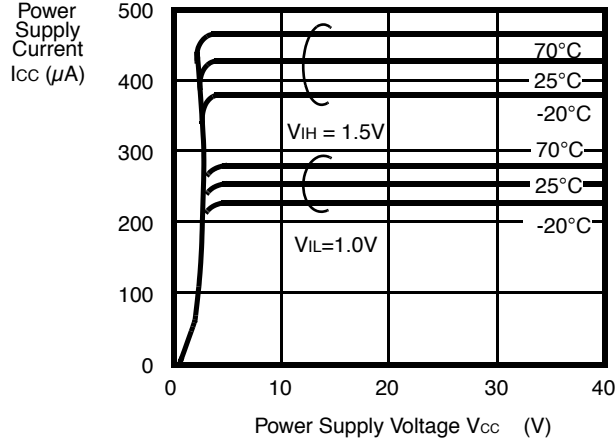

Fig. 4 - Hysteresis (A) Current vs Power Supply Voltage

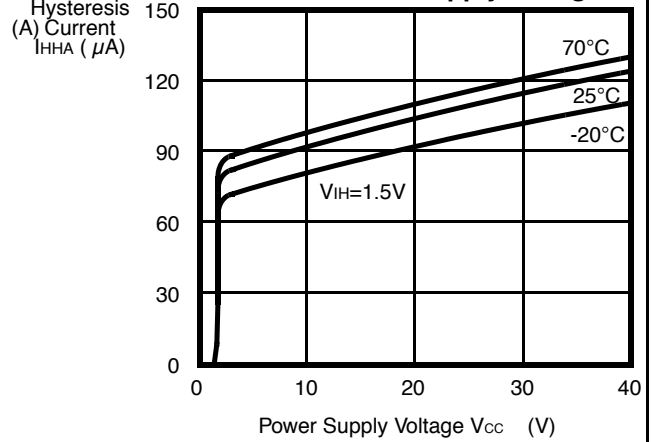

Fig. 5 - Output (A) Voltage vs. Output (A) Current

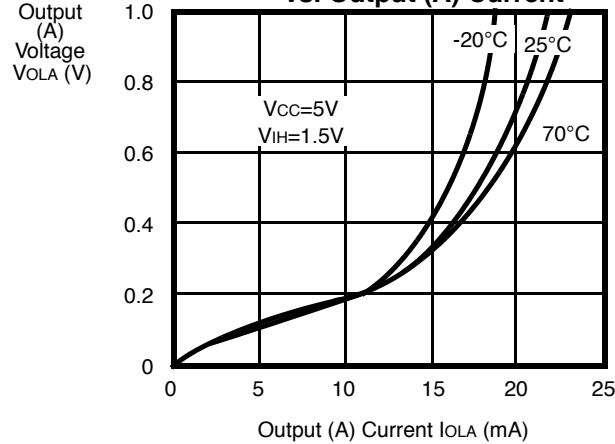

Fig. 6 - Output (B) Voltage vs. Output (B) Current

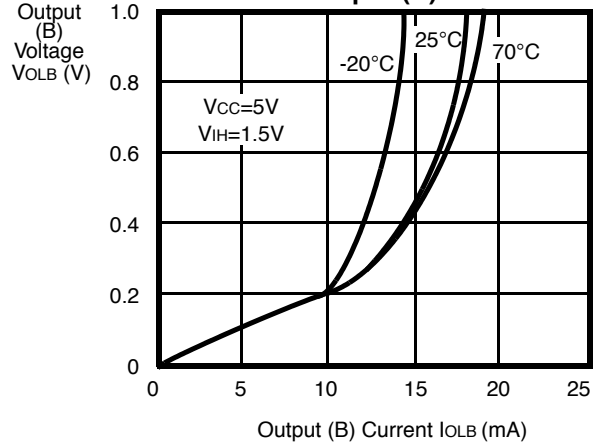

Fig. 7 - Threshold Voltage vs. Power Supply Voltage

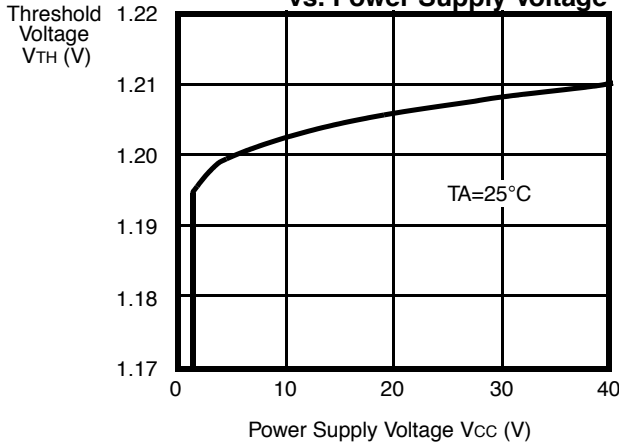
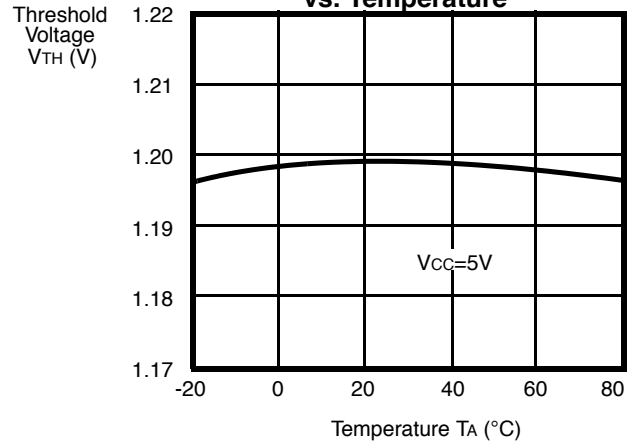
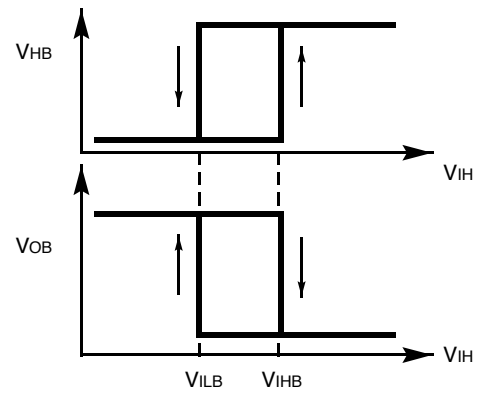
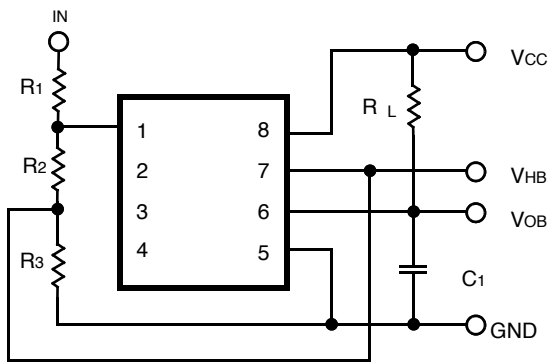
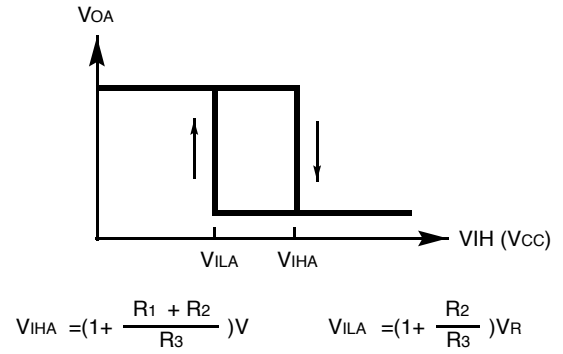
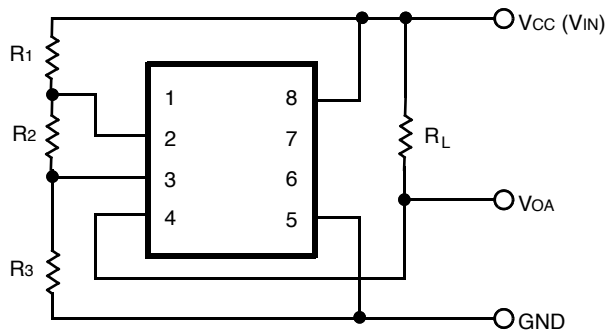

Fig. 8 - Threshold Voltage vs. Temperature



APPLICATION EXAMPLES

Figure 9. Addition of Hysteresis



Note: All calculations occur with the output voltage at 0. The hysteresis values are adjusted for load condition and saturation voltage.

■ APPLICATION EXAMPLES (Continued)

Figure 10. Voltage Detection for Alarm

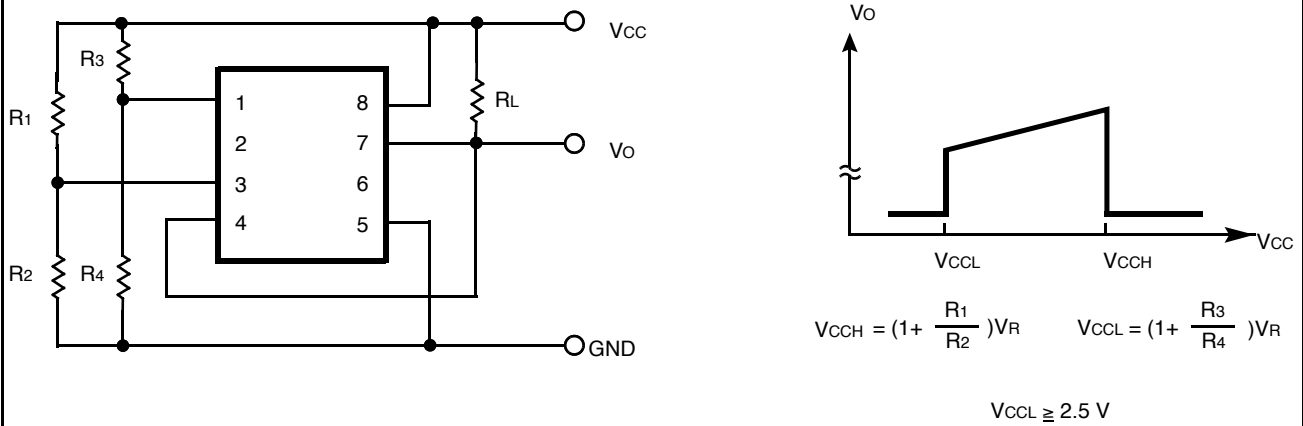

For hysteresis, a positive feedback from pin 2 or 7 is required.

Figure 11. Voltage Detection for Alarm

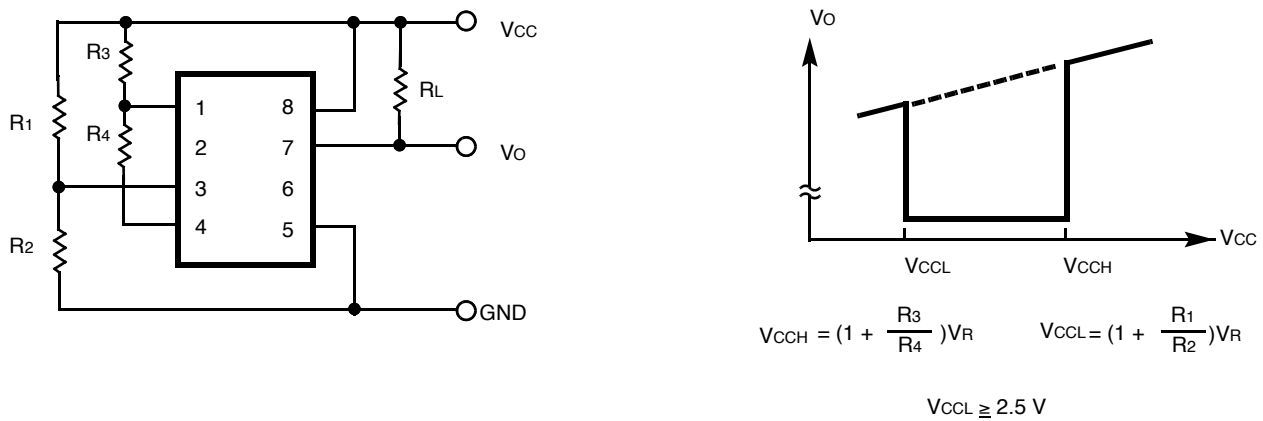

■ APPLICATION EXAMPLES (Continued)

Figure 12. Programmable Zener

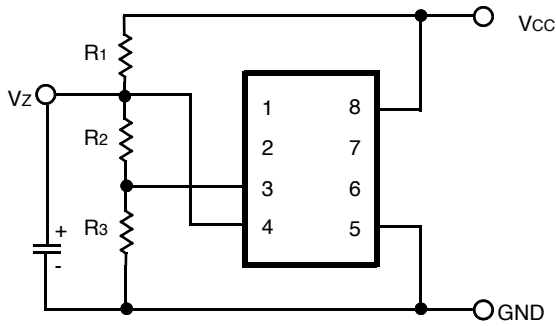

$$V_Z \approx \left(1 + \frac{R_2}{R_3}\right) V_R$$

$$\frac{V_Z}{R_2 + R_3} \leq \frac{V_{CC} - V_Z}{R_1} \leq 6\text{mA}$$

Channel B can be used independently.

Figure 13. Recovery Reset Circuit

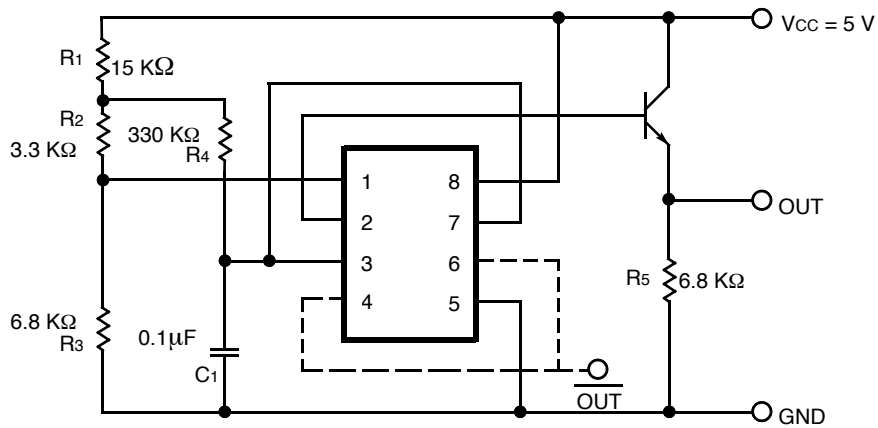

■ TYPICAL CHARACTERISTICS

Figure 14. DC Characteristics

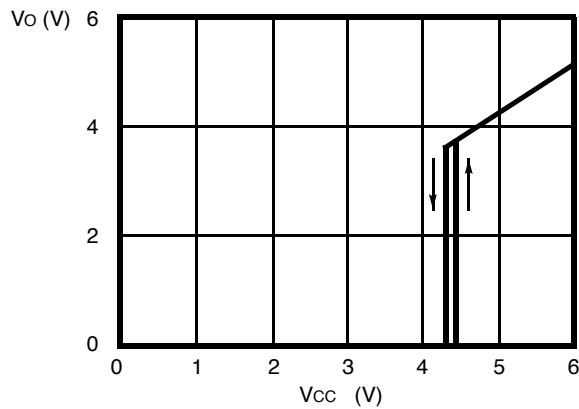
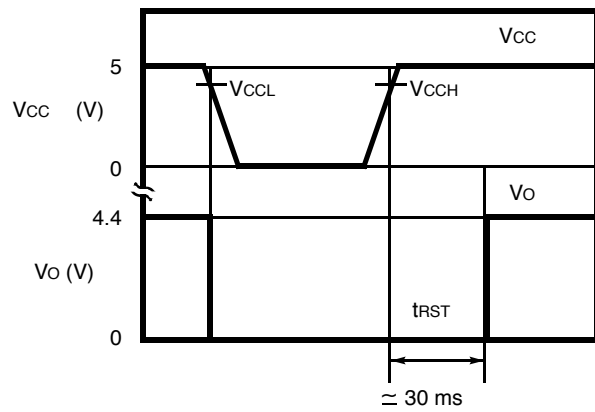

Figure 15. Response Characteristics



- Voltage Threshold Levels (V_{ccl} and V_{cch}) and Hysteresis Width can be changed by the resistors (R_1 through R_4).

$$V_{ccl} = \frac{R_1 + R_2 + R_3}{R_3} V_{TH}$$

$$V_{cch} = V_{ccl} + \frac{R_1 (R_2 + R_3)}{R_3 R_4} V_{TH}$$

- Power-On Reset Time is provided by the following approximate equation:

$$t_{rst} = -C_1 R_4 \cdot \ln \left\{ 1 - \frac{V_{TH}}{V_{CC}} \left(1 + \frac{R_1}{R_2 + R_3} \right) \right\}$$

- The recommended value of h_{FE} of the external transistor is from 50 to 200.
- In the case of an instant power fail, the remaining charge in C_1 effects t_{rst} .
- If necessary, the reversed output is provided on HYS terminal

■ PACKAGE DIMENSIONS (Continued)

8 pin, Plastic SIP
(SIP-08P-M03)

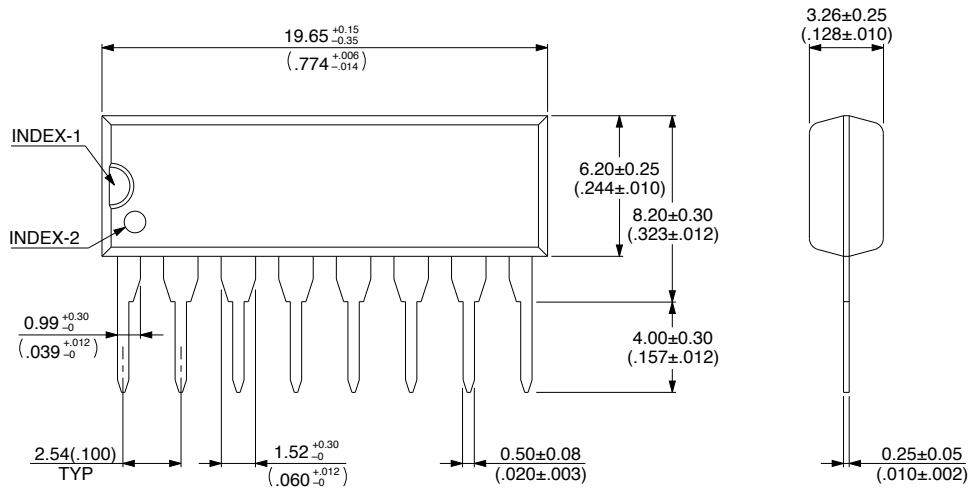

© 1994 FUJITSU LIMITED S08010S-3C-2

Dimensions in mm (inches).

■ PACKAGE DIMENSIONS (Continued)

8 pin, Plastic DIP
(DIP-08P-M01)

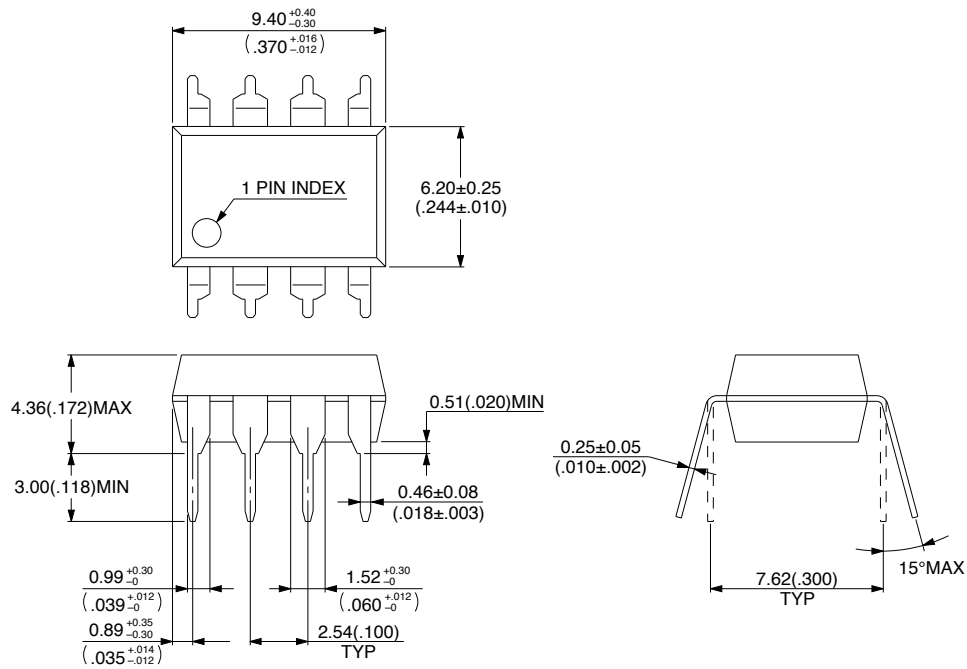

© 1994 FUJITSU LIMITED D08006S-2C-3

Dimensions in mm (inches).

MB3761

■ PACKAGE DIMENSIONS (Continued)

8 pin, Plastic SOP
(FPT-08P-M01)

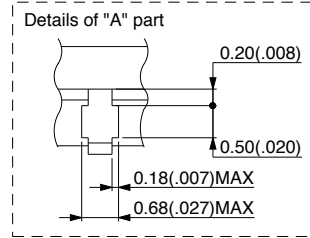
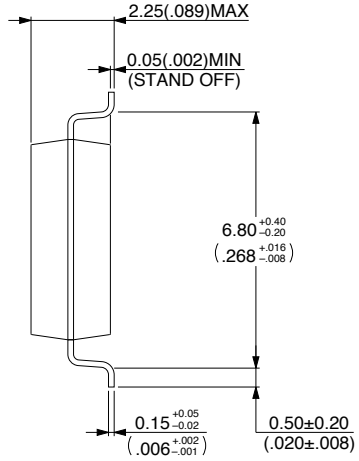
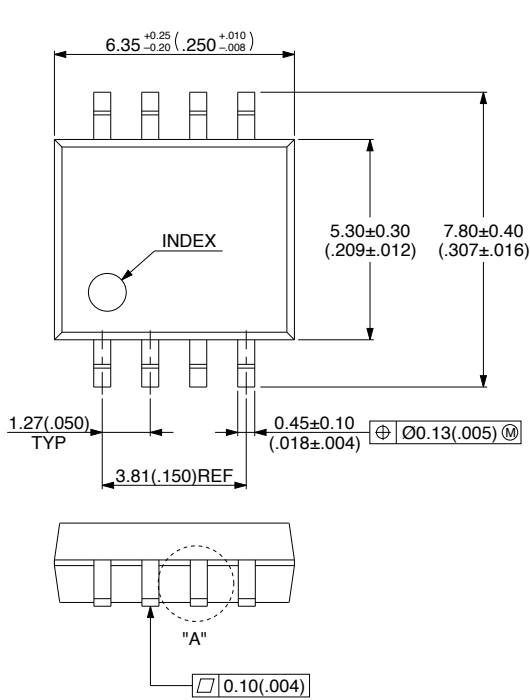

© 1994 FUJITSU LIMITED F08002S-4C-4

Dimensions in mm(inches).