

LXT300Z/LXT301Z

Advanced T1/E1 Short-Haul Transceivers

General Description

The LXT300Z and LXT301Z are fully integrated transceivers for both North American 1.544 Mbps (T1) and International 2.048 Mbps (E1) applications. They are pin and functionally compatible with standard LXT300/301 devices, with some circuit enhancements.

The LXT300Z provides receive jitter attenuation starting at 3 Hz, and is microprocessor controllable through a serial interface. The LXT301Z is pin compatible, but does not provide jitter attenuation or a serial interface. An advanced transmit driver architecture provides constant low output impedance for both marks and spaces, for improved Bit Error Rate performance over various cable network configurations. Both transceivers offer a variety of diagnostic features including transmit and receive monitoring. Clock inputs may be derived from an on-chip crystal oscillator or from digital inputs. They use an advanced double-poly, double-metal CMOS process and require only a single 5-volt power supply.

Applications

- PCM/Voice Channel Banks
- Data Channel Bank/Concentrator
- T1/E1 multiplexers
- Digital Access and Cross-connect Systems (DACs)
- Computer to PBX interfaces (CPI & DMI)
- High-speed data transmission lines
- Interfacing Customer Premises Equipment to a CSU
- Digital Loop Carrier (DLC) terminals

Features

- Data recovery and clock recovery functions
- Receive jitter attenuation starting at 3 Hz exceeds AT&T Pub 62411, Pub 43801, Pub 43802, ITU G.703, and ITU G.823 (LXT300Z only)
- Line driver with constant low mark and space impedance (3 Ω typical)
- Minimum receive signal of 500 mV
- Adaptive and selectable (E1/DSX-1) slicer levels for improved SNR
- Programmable transmit equalizer shapes pulses to meet DSX-1 pulse template from 0 to 655 feet or drive 120 Ω twisted pair or 75 Ω coax cable for E1
- Local and remote loopback functions
- Digital Transmit Driver Monitor
- Digital Receive Monitor with Loss of Signal (LOS) output and first mark reset
- Receiver jitter tolerance 0.4 UI from 40 kHz to 100 kHz
- Microprocessor controllable (LXT300Z only)
- Compatible with most popular PCM framers
- Available in 28-pin DIP or PLCC

LXT300Z/LXT301Z Block Diagram

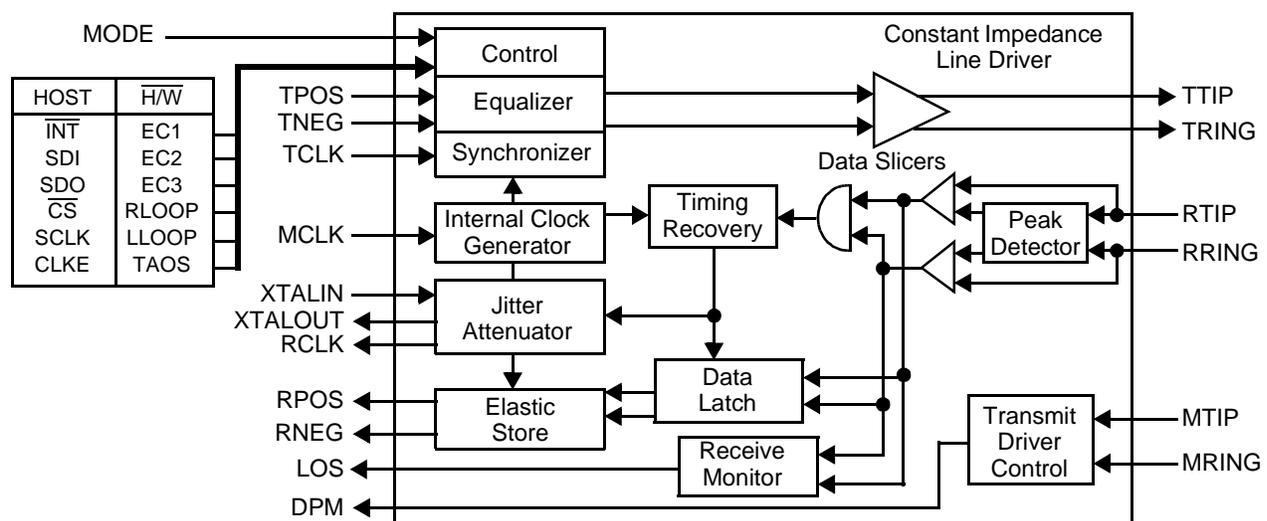

Refer to www.level1.com for most current information.

PIN ASSIGNMENTS AND SIGNAL DESCRIPTIONS

Figure 1: Pin Assignments

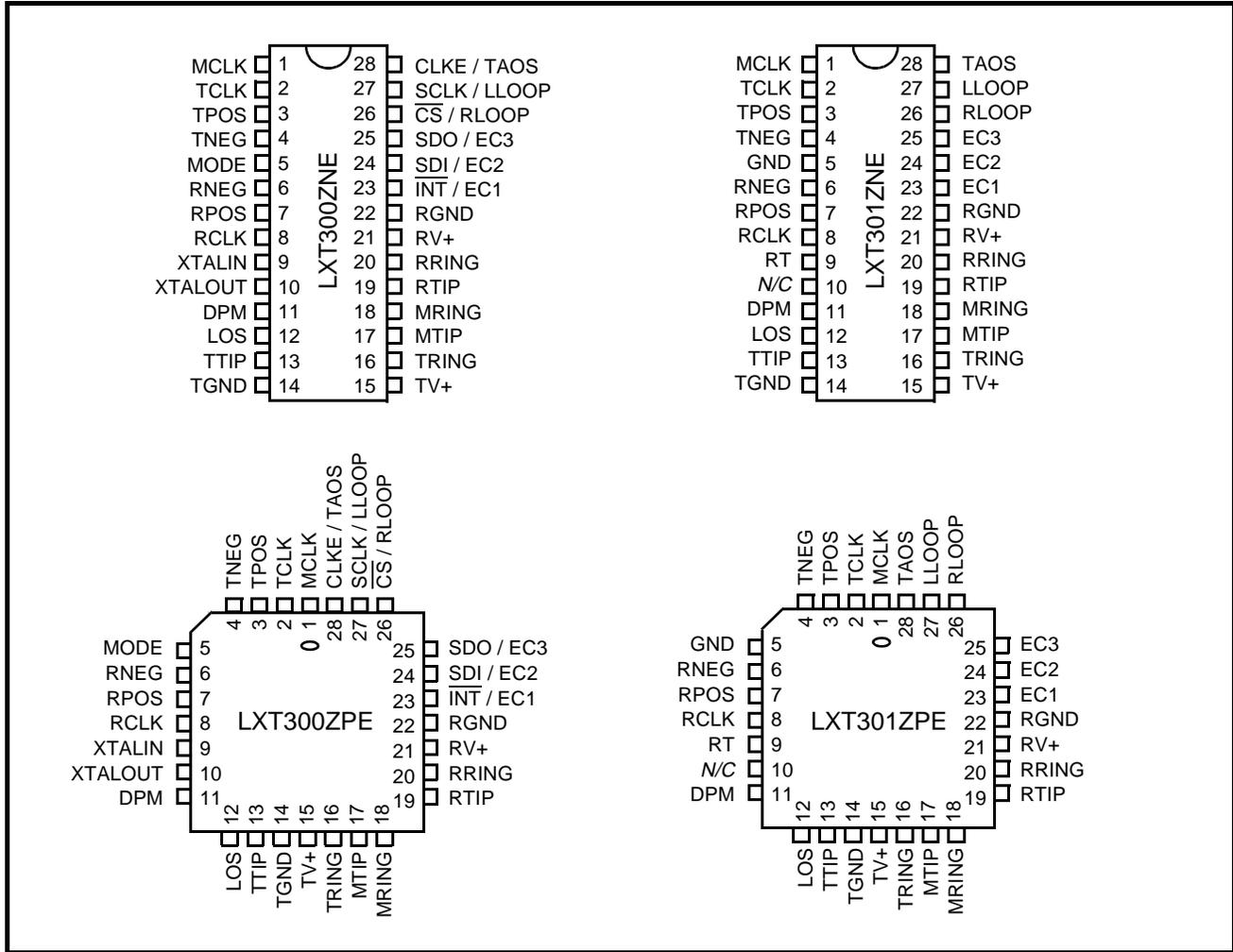

Table 1: Pin Descriptions

Pin #	Sym	I/O ¹	Description
1	MCLK	DI	Master Clock. A 1.544 or 2.048 MHz clock input used to generate internal clocks. Upon Loss of Signal (LOS), RCLK is derived from MCLK. <i>LXT300Z Only:</i> If MCLK is not applied, this pin must be grounded.
2	TCLK	DI	Transmit Clock. Transmit clock input. TPOS and TNEG are sampled on the falling edge of TCLK. If TCLK is grounded, the output drivers enter a high-Z state, except during Remote Loopback.
3	TPOS	DI	Transmit Positive Data. Input for positive pulse to be transmitted on the twisted-pair line or coax.

1. DI = Digital Input; DO = Digital Output; AI = Analog Input; AO = Analog Output; S = Supply.

Table 1: Pin Descriptions – continued

Pin #	Sym	I/O ¹	Description
4	TNEG	DI	Transmit Negative Data. Input for negative pulse to be transmitted on the twisted-pair line.
5	MODE	DI	Mode Select (LXT300Z). Setting MODE High puts the LXT300Z in the Host mode. In the Host mode, the serial interface is used to control the LXT300Z and determine its status. Setting MODE Low puts the LXT300Z in the Hardware (H/W) mode. In the Hardware mode, the serial interface is disabled and hard-wired pins are used to control configuration and report status.
	GND	S	Ground (LXT301Z). Tie to Ground.
6	RNEG	DO	Receive Negative Data; Receive Positive Data. Received data outputs. A signal on RNEG corresponds to receipt of a negative pulse on RTIP and RRING. A signal on RPOS corresponds to receipt of a positive pulse on RTIP and RRING. RNEG and RPOS outputs are Non-Return-to-Zero (NRZ). Both outputs are stable and valid on the rising edge of RCLK. <i>LXT300Z only:</i> In the Host mode, CLKE determines the clock edge at which these outputs are stable and valid. In the Hardware mode both outputs are stable and valid on the rising edge of RCLK.
7	RPOS	DO	
8	RCLK	DO	Recovered Clock. This is the clock recovered from the signal received at RTIP and RRING.
9	RT	AI	Receive Termination (LXT301Z). Connect to RV+ through a 1 k Ω resistor.
	XTALIN	AI	Crystal Input; Crystal Output (LXT300Z). An external crystal operating at four times the bit rate (6.176 MHz for DSX-1, 8.192 MHz for E1 applications with an 18.7 pF load) is required to enable the jitter attenuation function of the LXT300Z. These pins may also be used to disable the jitter attenuator by connecting the XTALIN pin to the positive supply through a resistor, and floating the XTALOUT pin.
10	XTALOUT	AO	
10	N/C	–	No Connection (LXT301Z).
11	DPM	DO	Driver Performance Monitor. DPM goes High when the transmit monitor loop (MTIP and MRING) does not detect a signal for 63 \pm 2 clock periods. DPM remains High until a signal is detected.
12	LOS	DO	Loss of Signal. LOS goes High when 175 consecutive spaces have been detected from receive. LOS returns Low when a mark is detected from the receiver.
13	TTIP	AO	Transmit Tip; Transmit Ring. Differential Driver Outputs. These outputs are designed to drive a 25 Ω load. The transmitter will drive 100 Ω shielded twisted-pair cable through a 1:2 step-up transformer without additional components. To drive 75 Ω coaxial cable, two 2.2 Ω resistors are required in series with the transformer.
16	TRING	AO	
14	TGND	S	Transmit Ground. Ground return for the transmit driver power supply TV+.
15	TV+	S	Transmit Driver Power Supply. +5 VDC power supply input for the transmit drivers. TV+ must not vary from RV+ by more than \pm 0.3 V.
17	MTIP	AI	Monitor Tip; Monitor Ring. These pins are used to monitor the tip and ring transmit outputs. The transceiver can be connected to monitor its own output or the output of another LXT300Z or LXT301Z on the board.
18	MRING	AI	

1. DI = Digital Input; DO = Digital Output; AI = Analog Input; AO = Analog Output; S = Supply.

Table 1: Pin Descriptions – continued

Pin #	Sym	I/O ¹	Description
19	RTIP	AI	Receive Tip; Receive Ring. The AMI signal received from the line is applied at these pins. A center-tapped, center-grounded, 2:1 step-up transformer is required on these pins. Data and clock from the signal applied at these pins are recovered and output on the RPOS/RNEG and RCLK pins.
20	RRING	AI	
21	RV+	S	Receive Power Supply. +5 VDC power supply for all circuits except the transmit drivers. (Transmit drivers are supplied by TV+.)
22	RGND	S	Receive Ground. Ground return for power supply RV+.
23	$\overline{\text{INT}}$	DO	Interrupt (LXT300Z - Host Mode). This output goes Low to flag the host processor when LOS or DPM go active. $\overline{\text{INT}}$ is an open-drain output and should be tied to power supply RV+ through a resistor. $\overline{\text{INT}}$ is reset by clearing the respective register bit (LOS and/or DPM).
	EC1	DI	Equalizer Control 1 (LXT301Z and LXT300Z - H/W Mode). The signal applied at this pin is used in conjunction with EC2 and EC3 inputs to determine shape and amplitude of AMI output transmit pulses.
24	SDI	DI	Serial Data In (LXT300Z - Host Mode). The serial data input stream is applied to this pin. SDI is sampled on the rising edge of SCLK.
	EC2	DI	Equalizer Control 2 (LXT301Z and LXT300Z - H/W Mode). The signal applied at this pin is used in conjunction with EC1 and EC3 inputs to determine shape and amplitude of AMI output transmit pulses.
25	SDO	DO	Serial Data Out (LXT300Z - Host Mode). The serial data from the on-chip register is output on this pin. If CLKE is High, SDO is valid on the rising edge of SCLK. If CLKE is Low SDO is valid on the falling edge of SCLK. This pin goes to a high-impedance state when the serial port is being written to and when $\overline{\text{CS}}$ is High.
	EC3	DI	Equalizer Control 3 (LXT301Z and LXT300Z - H/W Mode). The signal applied at this pin is used in conjunction with EC1 and EC2 inputs to determine shape and amplitude of AMI output transmit pulses.
26	$\overline{\text{CS}}$	DI	Chip Select (LXT300Z - Host Mode). This input is used to access the serial interface. For each read or write operation, $\overline{\text{CS}}$ must transition from High to Low, and remain Low.
	RLOOP	DI	Remote Loopback (LXT301Z and LXT300Z - H/W Mode). Setting RLOOP High enables the Remote Loopback mode. Setting both RLOOP and LLOOP High causes a Reset.

1. DI = Digital Input; DO = Digital Output; AI = Analog Input; AO = Analog Output; S = Supply.

Table 1: Pin Descriptions – continued

Pin #	Sym	I/O ¹	Description
27	SCLK	DI	Serial Clock (LXT300Z - Host Mode). This clock is used to write data to or read data from the serial interface registers.
	LLOOP	DI	Local Loopback (LXT301Z and LXT300Z - H/W Mode). This input controls loopback functions. Setting LLOOP High enables the Local Loopback mode.
28	CLKE	DI	Clock Edge (LXT300Z - Host Mode). Setting CLKE High causes RPOS and RNEG to be valid on the falling edge of RCLK, and SDO to be valid on the rising edge of SCLK. When CLKE is Low, RPOS and RNEG are valid on the rising edge of RCLK, and SDO is valid on the falling edge of SCLK.
	TAOS	DI	Transmit All Ones (LXT301Z and LXT300Z - H/W Mode). When High, a continuous stream of marks is transmitted at the TCLK frequency. Activating TAOS causes TPOS and TNEG inputs to be ignored. TAOS is inhibited during Remote Loopback.

1. DI = Digital Input; DO = Digital Output; AI = Analog Input; AO = Analog Output; S = Supply.

FUNCTIONAL DESCRIPTION

The LXT300Z and LXT301Z are fully integrated PCM transceivers for both 1.544 Mbps (DSX-1) and 2.048 Mbps (E1) applications. Both transceivers allow full-duplex transmission of digital data over existing twisted-pair or coax installations. The first page of this data sheet shows a simplified block diagram of the LXT300Z and Figure 2 shows the LXT301Z. The LXT301Z is similar to the LXT300Z, but does not incorporate the Jitter Attenuator and associated Elastic Store, nor the serial interface port.

The LXT300Z and LXT301Z transceivers each interface with two twisted-pair or coax lines (one pair or coax for transmit, one pair or coax for receive) through standard pulse transformers and appropriate resistors.

Power Requirements

The LXT300Z and LXT301Z are low-power CMOS devices. Each operates from a single +5 V power supply which can be connected externally to both the transmitter and receiver. However, the two inputs must be within $\pm 0.3V$ of each other, and decoupled to their respective grounds separately. Refer to "Application Information" on page 11 for typical decoupling circuitry. Isolation between the transmit and receive circuits is provided internally.

Reset Operation (LXT300Z and LXT301Z)

Upon power up, the transceiver is held static until the power supply reaches approximately 3 V. Upon crossing this threshold, the device begins a 32 ms reset cycle to calibrate the transmit and receive delay lines and lock the Phase Lock Loop (PLL) to the receive line. A reference clock is required to calibrate the delay lines. The transmitter reference is provided by TCLK. MCLK provides the receiver reference for the LXT301Z. The crystal oscillator provides the receiver reference in the LXT300Z. If the LXT300Z crystal oscillator is grounded, MCLK is used as the receiver reference clock.

The transceiver can also be reset from the Host mode or Hardware mode. In Host mode, reset is commanded by simultaneously writing RLOOP and LLOOP to the register. In Hardware mode, reset is commanded by holding RLOOP and LLOOP High simultaneously for 200 ns. Reset is initiated on the falling edge of the reset request. In either mode, the reset clears and sets all registers to 0 and then calibration begins.

Figure 2: LXT301Z Block Diagram

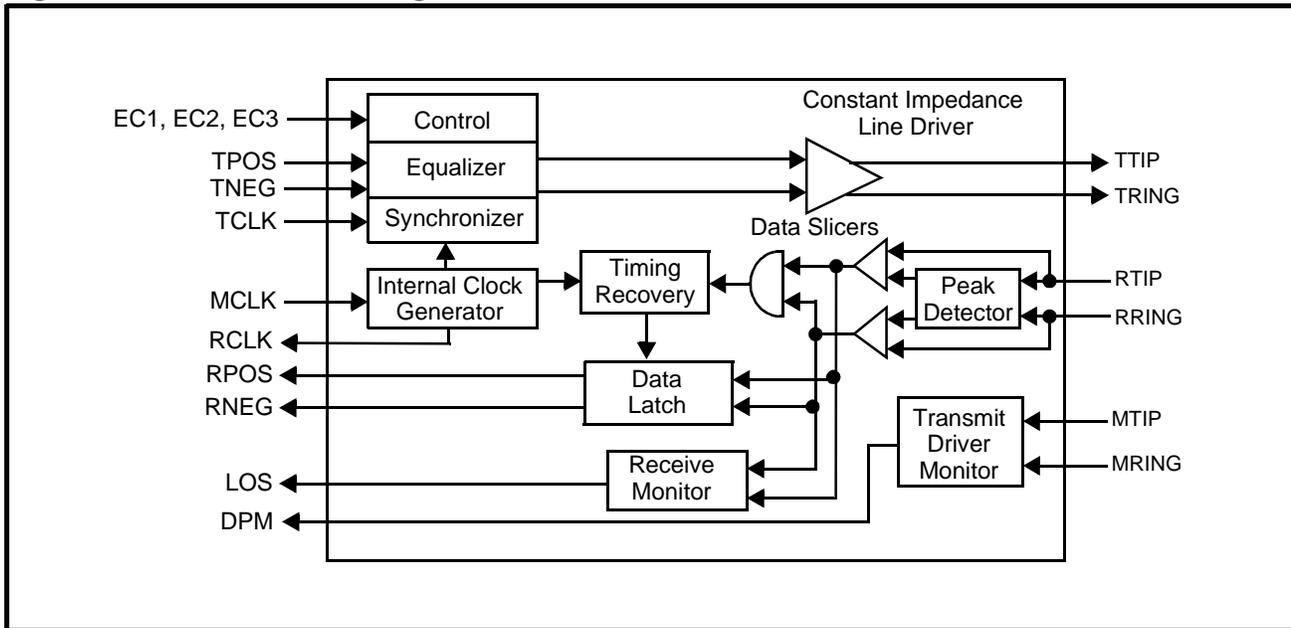

Receiver

The LXT300Z and LXT301Z receivers are identical except for the Jitter Attenuator and Elastic Store. The following discussion applies to both transceivers except where noted.

The signal is received from one twisted-pair line on each side of a center-grounded transformer. Positive pulses are received at RTIP and negative pulses are received at RRING. Recovered data is output at RPOS and RNEG, and the recovered clock is output at RCLK. Refer to the “Test Specifications” section of this data sheet for receiver timing.

The signal received at RPOS and RNEG is processed through the peak detector and data slicers. The peak detector samples the inputs and determines the maximum value of the received signal. A percentage of the peak value is provided to the data slicers as a threshold level to ensure optimum signal-to-noise ratio. For DSX-1 applications (determined by Equalizer Control inputs EC1~EC3 \neq 000) the threshold is set to 70% of the peak value. This threshold is maintained above 65% for up to 15 successive zeros over the range of specified operating conditions. For E1 applications (EC inputs = 000) the threshold is set to 50%.

The receiver is capable of accurately recovering signals with up to -13.6 dB of attenuation (from 2.4 V), corresponding to a received signal level of approximately 500 mV. Maximum line length is 1500 feet of ABAM cable (approximately 6 dB). Regardless of received signal level, the peak detectors are held above a minimum level of 300 mV to provide immunity from impulsive noise. Note that during a Loss of Signal (LOS) condition, RPOS and RNEG are squelched if the received input signal drops below 300 mV.

After processing through the data slicers, the received signal is routed to the data and clock recovery sections, and to the receive monitor. *In the LXT300Z only, recovered clock signals are supplied to the jitter attenuator and the data latch. The recovered data is passed to the elastic store where it is buffered and synchronized with the dejittered recovered clock (RCLK).* The data and clock recovery circuits have an input jitter tolerance significantly better than required by Pub 62411.

Receive (Loss of Signal) Monitor

The receive monitor generates a Loss of Signal (LOS) output upon receipt of 175 consecutive zeros (spaces). The receiver monitor loads a digital counter at the RCLK frequency. The count is incremented each time a zero is

received, and reset to zero each time a one (mark) is received. Upon receipt of 175 consecutive zeros the LOS pin goes High, and the RCLK output is replaced with MCLK. LOS is reset when the first mark is received.

(In the LXT300Z only, if MCLK is not supplied, the RCLK output will be replaced with the centered crystal clock.)

Jitter Attenuation (LXT300Z Only)

In the LXT300Z, recovered clock signals are supplied to the jitter attenuator and the data latch. The recovered data is passed to the elastic store where it is buffered and synchronized with the dejittered recovered clock (RCLK). Jitter attenuation of the LXT300Z clock and data outputs (see Figure 4) is provided by a Jitter Attenuation Loop (JAL) and an Elastic Store (ES). An external crystal oscillating at 4 times the bit rate provides clock stabilization. Refer to page 12 for crystal specifications. The ES is a 32 x 2-bit register. Recovered data is clocked into the ES with the recovered clock signal, and clocked out of the ES with the dejittered clock from the JAL. When the bit count in the ES is within two bits of overflowing or underflowing, the ES adjusts the output clock by 1/8 of a bit period. The ES produces an average delay of 16 bits in the receive path.

Transmitter

The transmitter circuits in the LXT300Z and LXT301Z are identical. The following discussion applies to both devices. Data received for transmission onto the line is clocked serially into the device at TPOS and TNEG. Input synchronization is supplied by the transmit clock (TCLK). The transmitted pulse shape is determined by Equalizer Control signals EC1 through EC3 as shown in Table 4. Refer to the “Test Specifications” section of this data sheet for master and transmit clock timing characteristics. Shaped pulses are applied to the AMI line driver for transmission onto the line at TTIP and TRING. Equalizer Control signals are hard-wired in the LXT301Z.

LXT300Z Only: Equalizer Control signals may be hardwired in the Hardware mode, or input as part of the serial data stream (SDI) in the Host mode.

Pulses can be shaped for either 1.544 or 2.048 Mbps applications. DSX-1 applications with 1.544 Mbps pulses can be programmed to match line lengths from 0 to 655 feet of ABAM cable. The LXT300Z and LXT301Z also match FCC specifications for CSU applications. Pulses at 2.048 Mbps can drive coaxial or shielded twisted-pair lines using appropriate resistors in line with the output transformer.

Driver Performance Monitor

The transceiver incorporates an advanced Driver Performance Monitor (DPM) in parallel with the TTIP and TRING at the output transformer. The DPM circuitry uses four comparators and a 150 ns pulse discriminator to filter glitches. The DPM output level goes High upon detection of 63 consecutive zeros, and is cleared when a one is detected on the transmit line, or when a reset command is received. The DPM output also goes High to indicate a ground on TTIP or TRING. A ground fault induced DPM flag is automatically cleared when the ground condition is corrected (chip reset is not required).

Line Code

The LXT300Z and LXT301Z transmit data as a 50% AMI line code as shown in Figure 3. Power consumption is reduced by activating the AMI line driver only to transmit a mark. The output driver is disabled during transmission of a space.

Operating Modes

The LXT300Z and LXT301Z transceivers can be controlled through hard-wired pins (Hardware mode). Both transceivers can also be commanded to operate in one of several diagnostic modes.

LXT300Z Only: The LXT300Z can be controlled by a microprocessor through a serial interface (Host mode). The mode of operation is set by the MODE pin logic level.

Host Mode Operation (LXT300Z Only)

To allow a host microprocessor to access and control the LXT300Z through the serial interface, MODE is set to 1. The serial interface (SDI/SDO) uses a 16-bit word consisting of an 8-bit Command/Address byte and an 8-bit Data byte. Figure 4 shows the serial interface data structure and relative timing.

The Host mode provides a latched Interrupt output ($\overline{\text{INT}}$) which is triggered by a change in the Loss of Signal (LOS) and/or Driver Performance Monitor (DPM) bits. The Interrupt is cleared when the interrupt condition no longer exists, and the host processor enables the respective bit in the serial input data byte. Host mode also allows control of the serial data and receive data output timing. The Clock Edge (CLKE) signal determines when these outputs are valid, relative to the Serial Clock (SCLK) or RCLK as listed in Table 3.

The LXT300Z serial port is addressed by setting bit A4 in the Address/Command byte, corresponding to address 16. The LXT300Z contains only a single output data register so no complex chip addressing scheme is required. The register is accessed by causing the Chip Select ($\overline{\text{CS}}$) input to transition from High to Low. Bit 1 of the serial Address/Command byte provides Read/Write control when the chip is accessed. A logic 1 indicates a read operation, and a logic 0 indicates a write operation. Table 4 lists serial data output bit combinations for each status. Serial data I/O timing characteristics are shown in the Test Specifications section.

Hardware Mode Operation (LXT300Z and LXT301Z)

In Hardware mode the transceiver is accessed and controlled through individual pins. With the exception of the $\overline{\text{INT}}$ and CLKE functions, Hardware mode provides all the functions provided in the Host mode. In the Hardware mode RPOS and RNEG outputs are valid on the rising edge of RCLK. The LXT301Z operates in Hardware mode at all times.

LXT300Z Only: To operate in Hardware mode, MODE must be set Low. Equalizer Control signals (EC1 through EC3) are input on the Interrupt, Serial Data In and Serial Data Out pins respectively. Diagnostic control for Remote Loopback (RLOOP), Local Loopback (LLOOP), and Transmit All Ones (TAOS) modes is provided through the individual pins used to control serial interface timing in the Host mode.

Figure 3: 50% AMI Coding

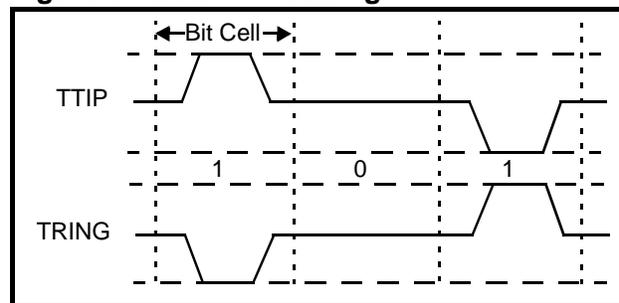

Table 2: LXT300Z Serial Data Output Bits (See Figure 4)

Bit D5	Bit D6	Bit D7	Status
0	0	0	Reset has occurred, or no program input.
0	0	1	TAOS is active.
0	1	0	Local Loopback is active.
0	1	1	TAOS and Local Loopback are active.
1	0	0	Remote Loopback is active.
1	0	1	DPM has changed state since last Clear DPM occurred.
1	1	0	LOS has changed state since last Clear LOS occurred.
1	1	1	LOS and DPM have both changed state since last Clear DPM and Clear LOS occurred.

Table 3: Valid CLKE Settings

CLKE	Output	Clock	Valid Edge
Low	RPOS	RCLK	Rising
	RNEG	RCLK	Rising
	SDO	SCLK	Falling
High	RPOS	RCLK	Falling
	RNEG	RCLK	Falling
	SDO	SCLK	Rising

Table 4: Equalizer Control Inputs

EC3	EC2	EC1	Line Length ¹	Cable Loss ²	Application	Bit Rate
0	1	1	0 ~ 133 ft ABAM	0.6 dB	DSX-1	1.544 Mbps
1	0	0	133 ~ 266 ft ABAM	1.2 dB		
1	0	1	266 ~ 399 ft ABAM	1.8 dB		
1	1	0	399 ~ 533 ft ABAM	2.4 dB		
1	1	1	533 ~ 655 ft ABAM	3.0 dB		
0	0	0	ITU Recommendation G.703		E1	2.048 Mbps
0	1	0	FCC Part 68, Option A		CSU	1.544 Mbps

1. Line length from transceiver to DSX-1 cross-connect point.
2. Maximum cable loss at 772 kHz.

Diagnostic Mode Operation

Transmit All Ones

In Transmit All Ones (TAOS) mode, the TPOS and TNEG inputs to the transceiver are ignored. The

transceiver transmits a continuous stream of ones. TAOS can be commanded simultaneously with Local Loopback, but is inhibited during Remote Loopback.

Remote Loopback

In Remote Loopback (RLOOP) mode, the transmit data and clock inputs (TPOS, TNEG and TCLK) are ignored. The RPOS and RNEG outputs are looped back through the transmit circuits and output on TTIP and TRING at the RCLK frequency. Receiver circuits are unaffected by the RLOOP command and continue to output the RPOS, RNEG and RCLK signals received from the twisted-pair line.

Local Loopback

In Local Loopback (LLOOP) mode, the receiver circuits are inhibited. The transmit data and clock inputs (TPOS, TNEG and TCLK) are looped back onto the receive data and clock outputs (RPOS, RNEG and RCLK) through the receive jitter attenuator. The transmitter circuits are unaffected by the LLOOP command. The TPOS and TNEG inputs (or a stream of ones if the TAOS command is active) will be transmitted normally.

LXT300Z Only: When used in this mode with a crystal, the transceiver can be used as a stand-alone jitter attenuator.

Figure 4: LXT300Z Serial Interface Data Structure

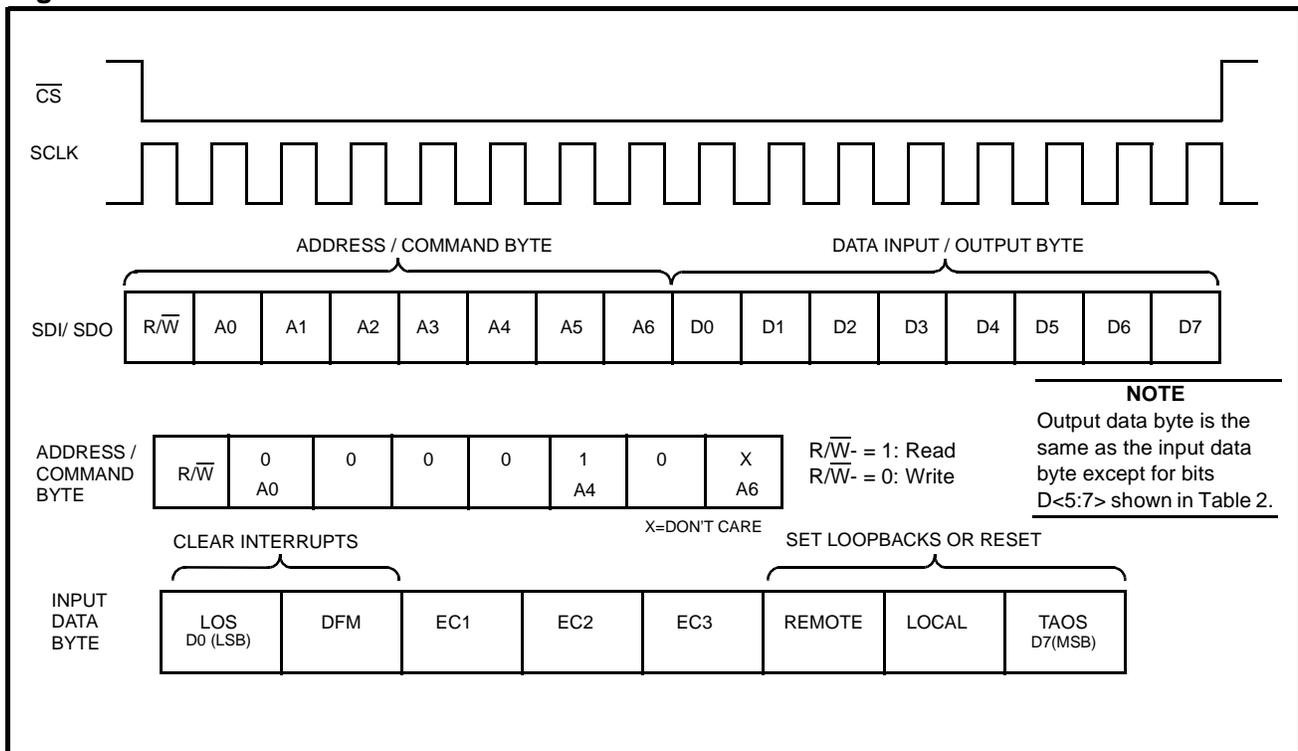

APPLICATION INFORMATION

LXT300Z Host Mode 1.544 Mbps T1 Interface

Figure 5 shows a typical 1.544 Mbps T1 application. The LXT300Z is configured in the Host mode with a typical T1/ESF framer providing the digital interface with the host controller. Both devices are controlled through the serial

interface. The LXP600A Clock Adapter (CLAD) provides the 2.048 MHz system backplane clock, locked to the recovered 1.544 MHz clock signal. The power supply inputs are tied to a common bus with appropriate decoupling capacitors installed (68 μ F on the transmit side, 1.0 μ F and 0.1 μ F on the receive side).

Figure 5: Typical LXT300Z 1.544 Mbps T1 Application (Host Mode)

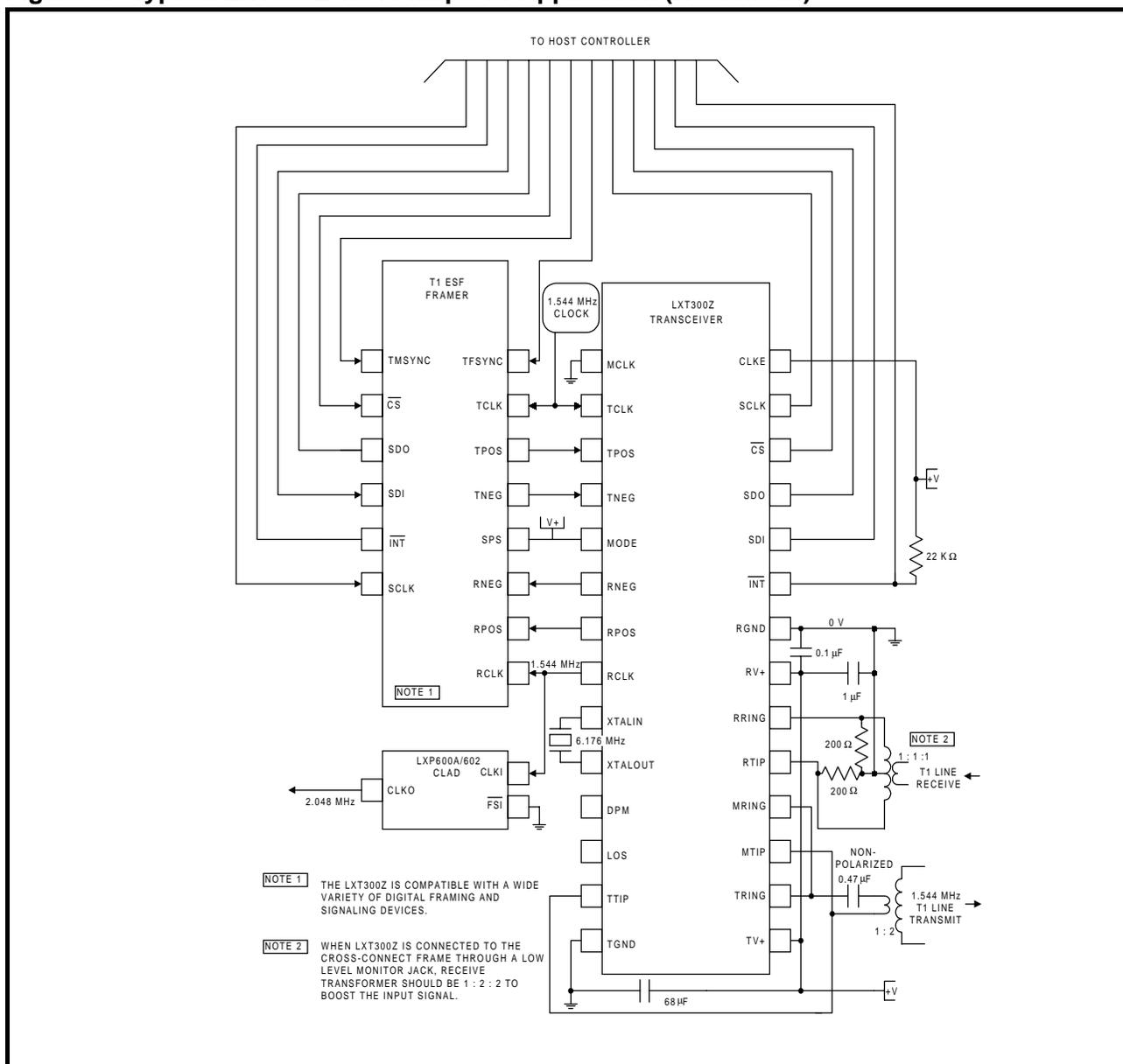

LXT300Z Hardware Mode E1 Interface Application

Figure 6 shows a typical 2.048 Mbps E1 application. The LXT300Z is configured in Hardware mode with a typical E1/CRC4 framer. Resistors are installed in line with the transmit transformer for loading a 75 Ω coaxial cable. The in-line resistors are not required for transmission on 120 Ω

shielded twisted-pair lines. As in the T1 application shown in Figure 5, this configuration is illustrated with a crystal in place to enable the LXT300Z Jitter Attenuation Loop, and a single power supply bus. The hard-wired control lines for TAOS, LLOOP and RLOOP are individually controllable, and the LLOOP and RLOOP lines are also tied to a single control for the Reset function

Figure 6: Typical LXT300Z 75 Ω E1 Application (Hardware Mode)

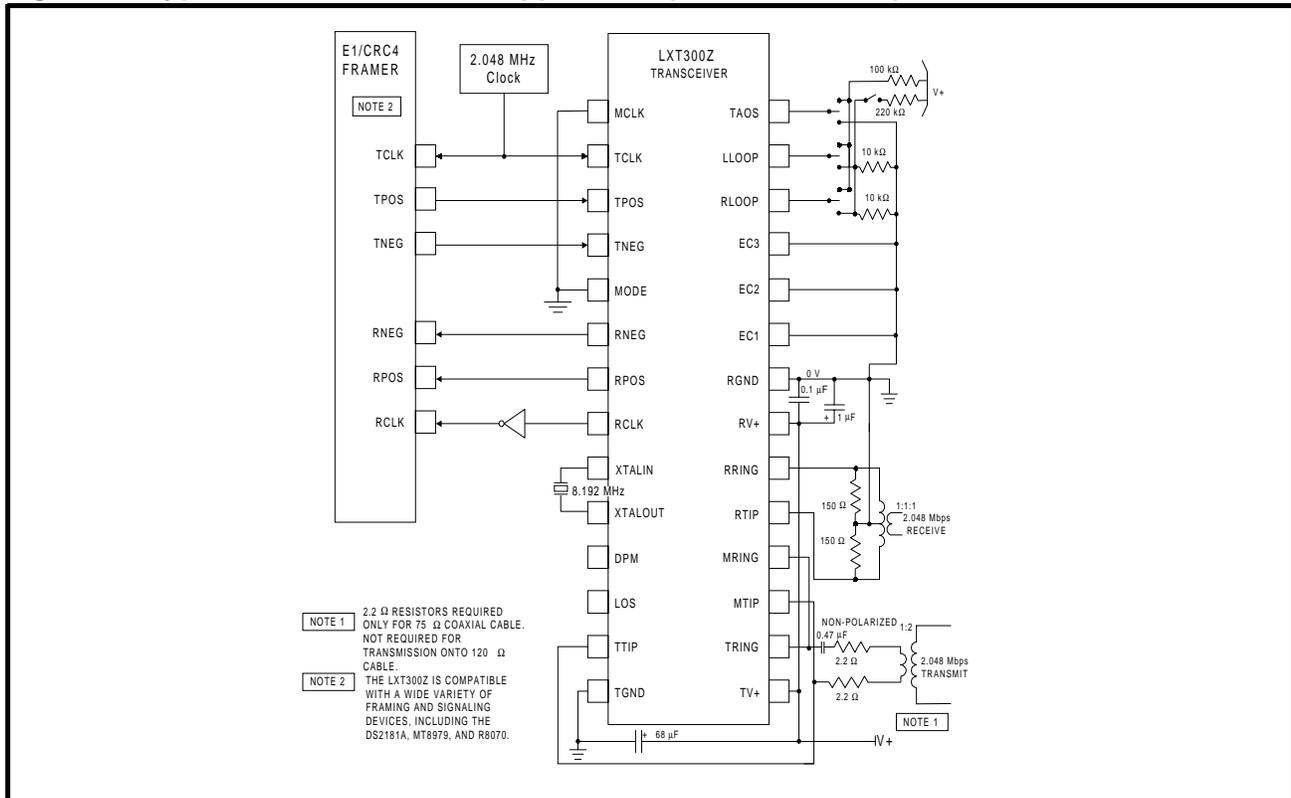

Table 5: LXT300Z Crystal Specifications (External)

Parameter	T1	E1
Frequency	6.176 MHz	8.192 MHz
Frequency stability	± 20 ppm @ 25 °C ± 25 ppm from -40 °C to 85 °C (Ref 25 °C reading)	± 20 ppm @ 25 °C ± 25 ppm from -40 °C to +85 °C (Ref 25 °C reading)
Pullability	CL = 11 pF to 18.7 pF, +ΔF = 175 to 195 ppm CL = 18.7 pF to 34 pF, -ΔF = 175 to 195 ppm	CL = 11 pF to 18.7 pF, +ΔF = 95 to 115 ppm CL = 18.7 pF to 34 pF, -ΔF = 95 to 115 ppm
Effective series resistance	40 Ω Maximum	30 Ω Maximum
Crystal cut	AT	AT
Resonance	Parallel	Parallel
Maximum drive level	2.0 mW	2.0 mW
Mode of operation	Fundamental	Fundamental
Crystal holder	HC49 (R3W), Co = 7 pF maximum CM = 17 fF typical	HC49 (R3W), Co = 7 pF maximum CM = 17 fF typical

LXT301Z 1.544 Mbps T1 Interface Application

Figure 7 shows a typical 1.544 Mbps T1 application of the LXT301Z. The LXT301Z is shown with a typical T1/ESF framer. The LXP600A Clock Adapter (CLAD) provides

the 2.048 MHz system backplane clock, locked to the recovered 1.544 MHz clock signal. The power supply inputs are tied to a common bus with appropriate decoupling capacitors installed (68 μ F on the transmit side, 1.0 μ F and 0.1 μ F on the receive side).

Figure 7: Typical LXT301Z 1.544 Mbps T1 Application

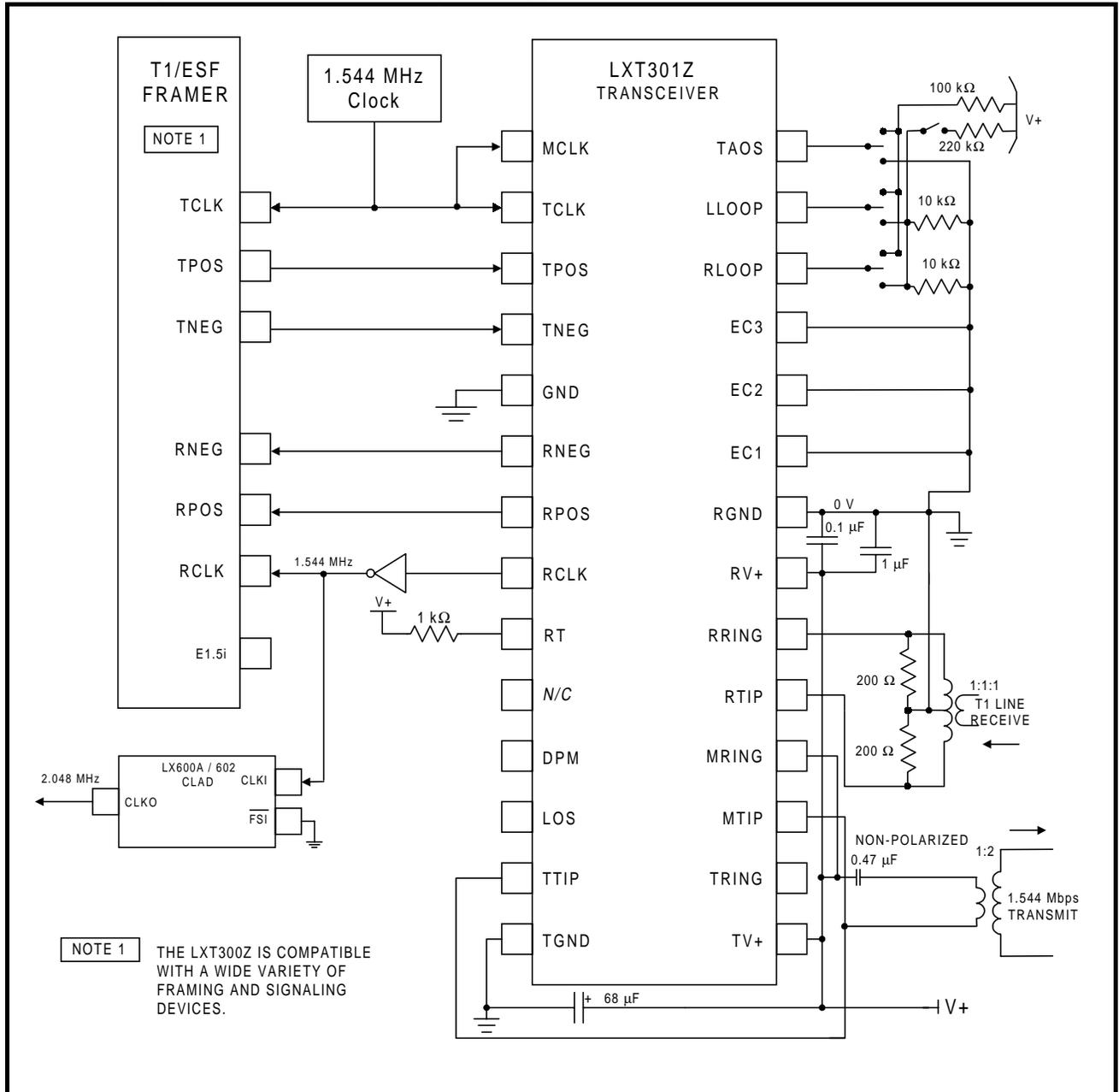

LXT301Z 2.048 Mbps E1 Interface Application

Figure 8 shows a typical 2.048 Mbps E1 application of the LXT301Z. The LXT301Z is shown with a typical E1/CRC4 framer. Resistors are installed in line with the transmit transformer for loading a 75 Ω coaxial cable. The in-line resistors are not required for transmission on 120 Ω

shielded twisted-pair lines. As in the T1 application shown in Figure 7, this configuration is illustrated with a single power supply bus. The hard-wired control lines for TAOS, LLOOP and RLOOP are individually controllable, and the LLOOP and RLOOP lines are also tied to a single control for the Reset function.

Figure 8: Typical LXT301Z 75 Ω E1 Application

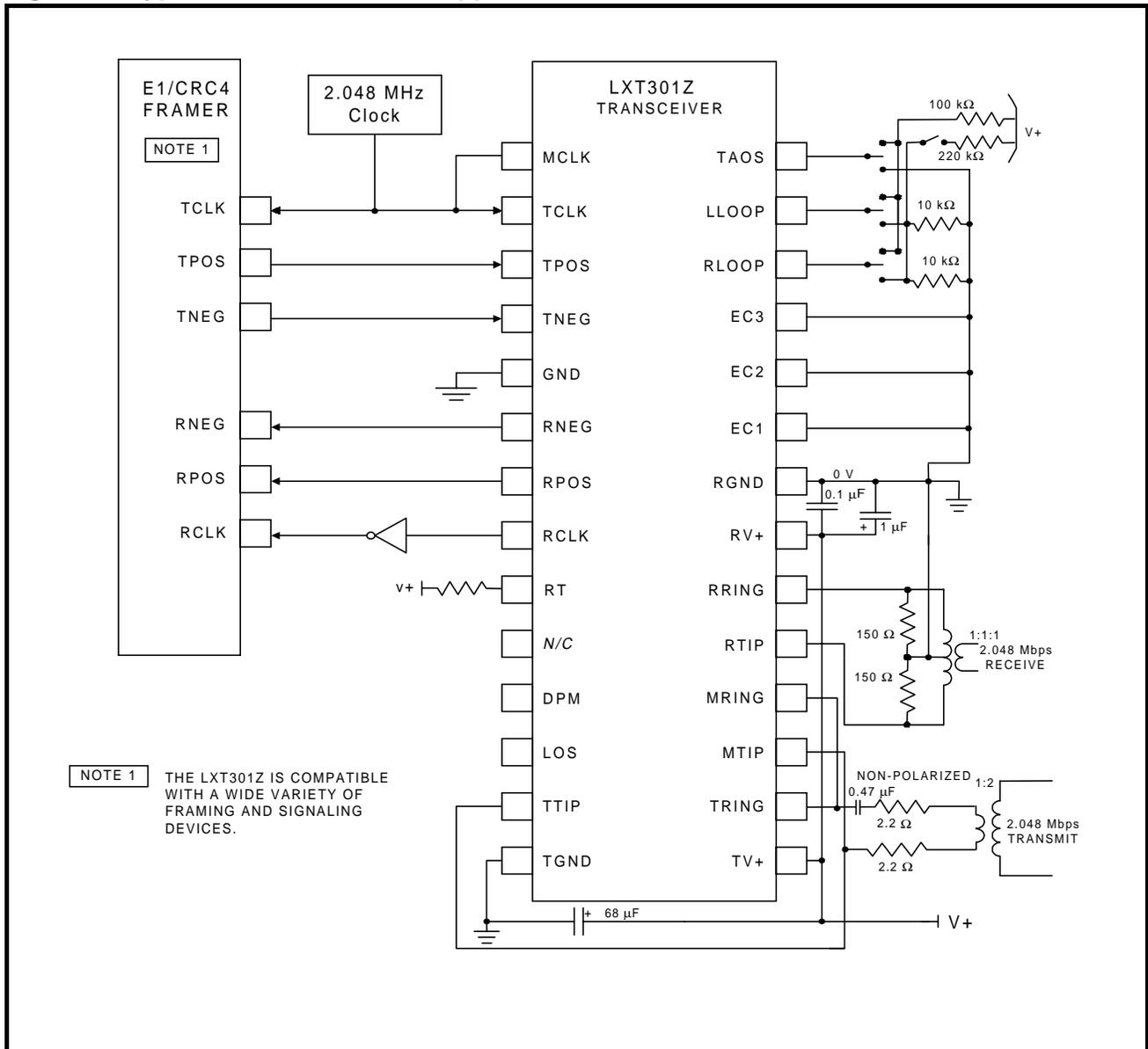

TEST SPECIFICATIONS

NOTE

Tables 6 through 13 and Figures 9 through 15 represent the performance specifications of the LXT300Z/301Z and are guaranteed by test except, where noted, by design. The minimum and maximum values listed in Tables 8 through 13 are guaranteed over the recommended operating conditions specified in Table 7.

Table 6: Absolute Maximum Ratings

Parameter	Sym	Min	Max	Units
DC supply (referenced to GND)	RV+, TV+	-0.3	6.0	V
Input voltage, any pin ¹	VIN	RGND - 0.3	RV+ + 0.3	V
Input current, any pin ²	IIN	-10	10	mA
Storage temperature	TSTG	-65	150	°C
CAUTION Exceeding these values may cause permanent damage. Functional operation under these conditions is not implied. Exposure to maximum rating conditions for extended periods may affect device reliability.				
1. Excluding RTIP and RRING which must stay between -6V and (RV+ + 0.3) V. 2. Transient currents of up to 100 mA will not cause SCR latch up. TTIP, TRING, TV+ and TGND can withstand a continuous current of 100 mA.				

Table 7: Recommended Operating Conditions

Parameter	Sym	Min	Typ	Max	Units
DC supply ¹	RV+, TV+	4.75	5.0	5.25	V
Ambient operating temperature	TA	-40	25	85	°C
1. TV+ must not exceed RV+ by more than 0.3 V.					

Table 8: Electrical Characteristics

Parameter	Sym	Min	Typ	Max	Units	Test Conditions
High level input voltage ^{1,2} (pins 1-5, 10, 23-28)	V _{IH}	2.0	–	–	V	
Low level input voltage ^{1,2} (pins 1-5, 10, 23-28)	V _{IL}	–	–	0.8	V	
High level output voltage ^{1,2} (pins 6-8, 11, 12, 23, 25)	V _{OH}	2.4	–	–	V	I _{OUT} = -400 μA
Low level output voltage ^{1,2} (pins 6-8, 11, 12, 23, 25)	V _{OL}	–	–	0.4	V	I _{OUT} = 1.6 mA
Input leakage current (pins 1-5, and 23-28)	I _{LL}	-10	–	+10	μA	
Input leakage current (pins 9, 17, and 18)	I _{LL}	-50	–	+50	μA	
Three-state leakage current ¹ (pin 25)	I _{3L}	-10	–	+10	μA	
Total power dissipation ³	PD	–	–	700	mW	100% ones density & maximum line length @ 5.25 V

1. Functionality of pins 23 through 28 depends on mode. See Host and Hardware mode functional descriptions.
2. Output drivers will output CMOS logic levels into CMOS loads.
3. Power dissipation while driving a 25 Ω load over operating temperature range. Includes device and load. Digital input levels are within 10% of the supply rails and digital outputs are driving a 50 pF capacitive load.

Table 9: Analog Characteristics

Parameter	Min	Typ ¹	Max	Units	Test Conditions	
AMI output pulse amplitudes	DSX-1	2.4	3.0	3.6	V	measured at the DSX
	E1 (120 Ω)	2.7	3.0	3.3	V	measured at line side
	E1 (75 Ω)	2.14	2.37	2.6	V	@ 772 kHz
Transmit amplitude variation with supply		1	2.5	%		
Recommended output load at TTIP and TRING	–	25	–	Ω	RTIP to RRING	
Driver output impedance ²	–	3	10	Ω	@ 10 kHz	
Jitter added by the transmitter ³	10 Hz - 8 kHz ²	–	–	0.02	UI	
	8 kHz - 40 kHz	–	–	0.025	UI	
	10 Hz - 40 kHz	–	–	0.025	UI	
	Broad Band	–	–	0.05	UI	
Output power levels ²	@ 772 kHz	12.6	–	17.9	dBm	
	DS1 2 kHz BW @ 1544 kHz ⁵	-29.0	–	–	dB	
Positive to negative pulse imbalance	–	–	0.5	dB		
Sensitivity below DSX ⁶ (0 dB = 2.4 V)		13.6	–	–	dB	
		500	–	–	mV	
Receiver input impedance	–	40	–	kΩ		

1. Typical values are measured at 25 °C and are for design aid only; not guaranteed and not subject to production testing.
2. Not production tested but guaranteed by design and other correlation methods.
3. Input signal to TCLK is jitter-free.
4. Circuit attenuates jitter at 20 dB/decade above the corner frequency.
5. Referenced to power in 2 kHz band.
6. With a maximum of 6 dB of cable attenuation.

Table 9: Analog Characteristics – continued

Parameter		Min	Typ ¹	Max	Units	Test Conditions
Loss of Signal threshold		–	0.3	–	V	
Data decision threshold	DSX-1	63	70	77	% peak	
	E1	43	50	57	% peak	
Allowable consecutive zeros before LOS		160	175	190	–	
Input jitter tolerance	10 Hz	–	1200	–	UI	
	775 Hz	14	–	–	UI	
	10 kHz - 100 kHz	0.4	–	–	UI	
Jitter attenuation curve corner frequency ⁴		–	3	–	Hz	
Jitter attenuation		–	50	–	db	
Jitter attenuation tolerance before FIFO Overflow ²		28	–	–	UI	
<p>1. Typical values are measured at 25 °C and are for design aid only; not guaranteed and not subject to production testing.</p> <p>2. Not production tested but guaranteed by design and other correlation methods.</p> <p>3. Input signal to TCLK is jitter-free.</p> <p>4. Circuit attenuates jitter at 20 dB/decade above the corner frequency.</p> <p>5. Referenced to power in 2 kHz band.</p> <p>6. With a maximum of 6 dB of cable attenuation.</p>						

Figure 9: LXT300Z Typical Receive Jitter Tolerance

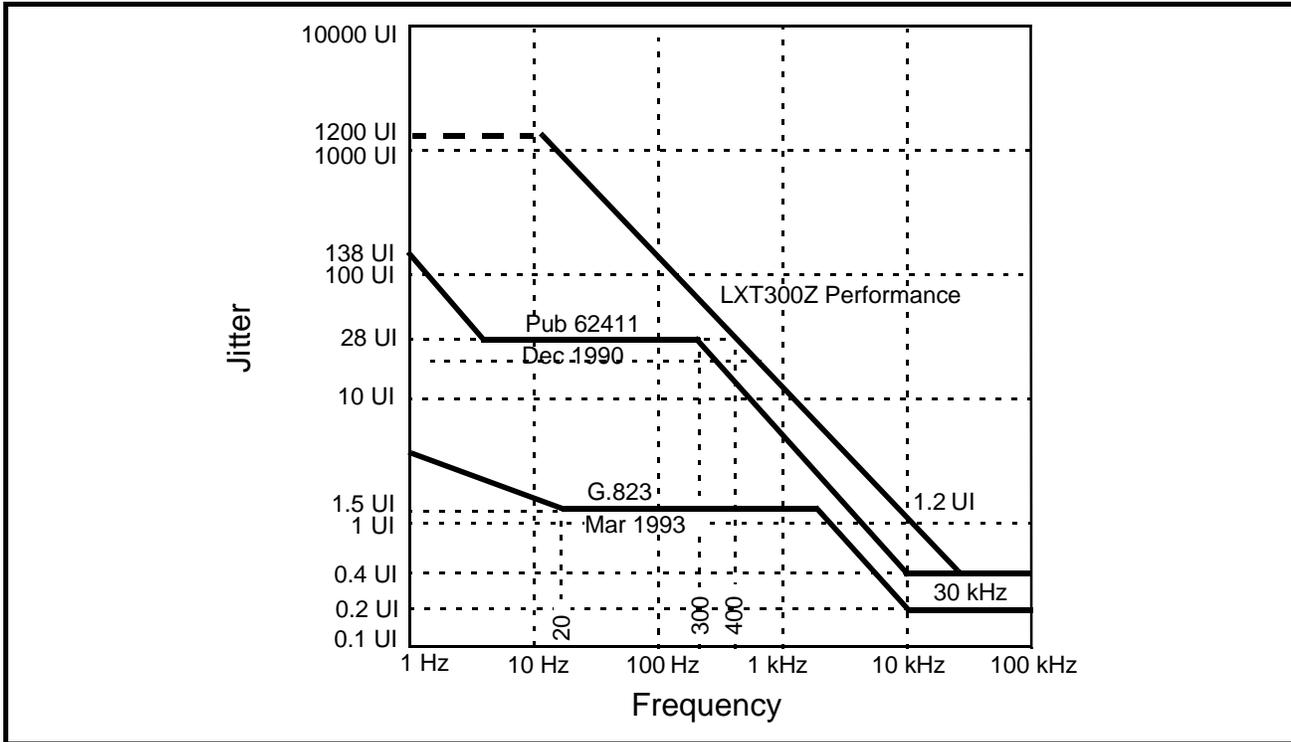

Figure 10: LXT300Z Typical Receive Jitter Transfer Performance

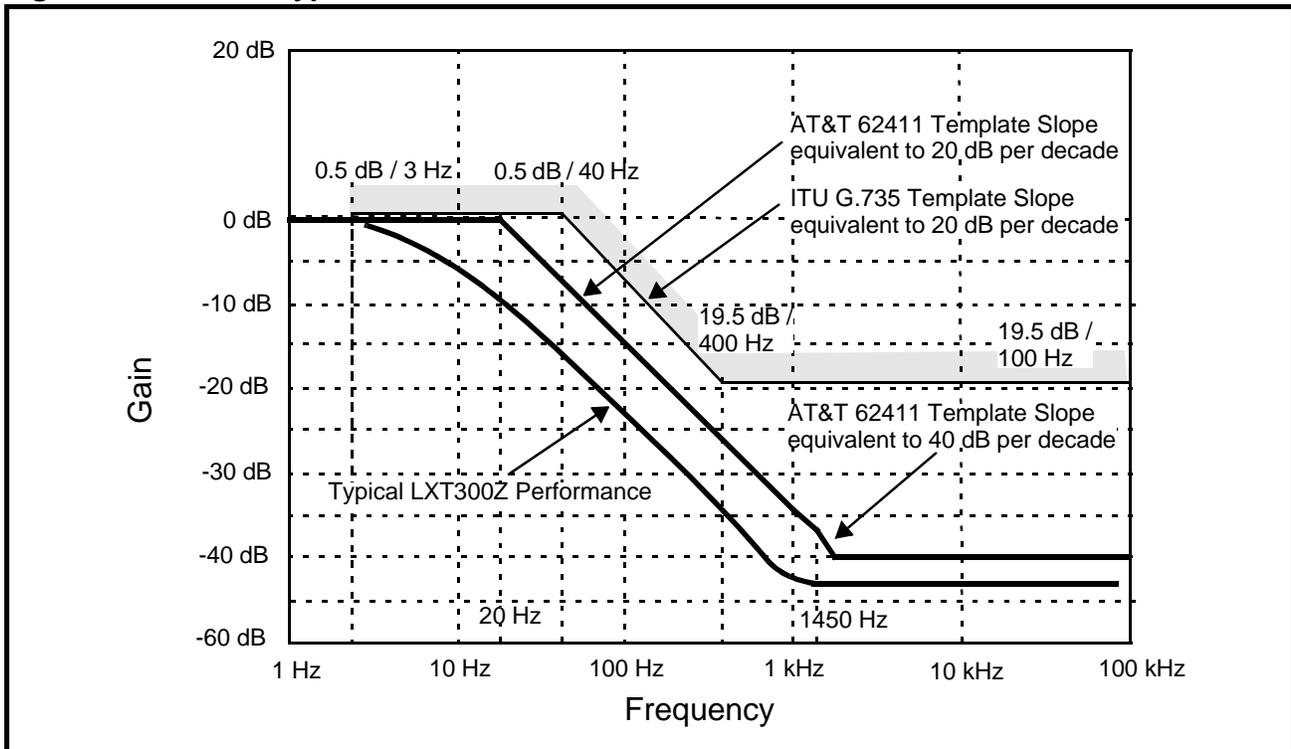

Table 10: LXT300Z Receiver Timing Characteristics (See Figure 11)

Parameter	Sym	Min	Typ ¹	Max	Units	Test Conditions
Receive clock duty cycle	RCLKd	40	-	60	%	
Receive clock pulse width ²	DSX-1	tPW	-	324	-	ns
	E1	tPW	-	244	-	ns
RPOS/RNEG to RCLK rising setup time	DSX-1	tSUR	-	274	-	ns
	E1	tSUR	-	194	-	ns
RCLK rising to RPOS/RNEG hold time	DSX-1	tHR	-	274	-	ns
	E1	tHR	-	194	-	ns

1. Typical values are at 25 °C and are for design aid only; they are not guaranteed and not subject to production testing.

Figure 11: LXT300Z Receive Clock Timing Diagram

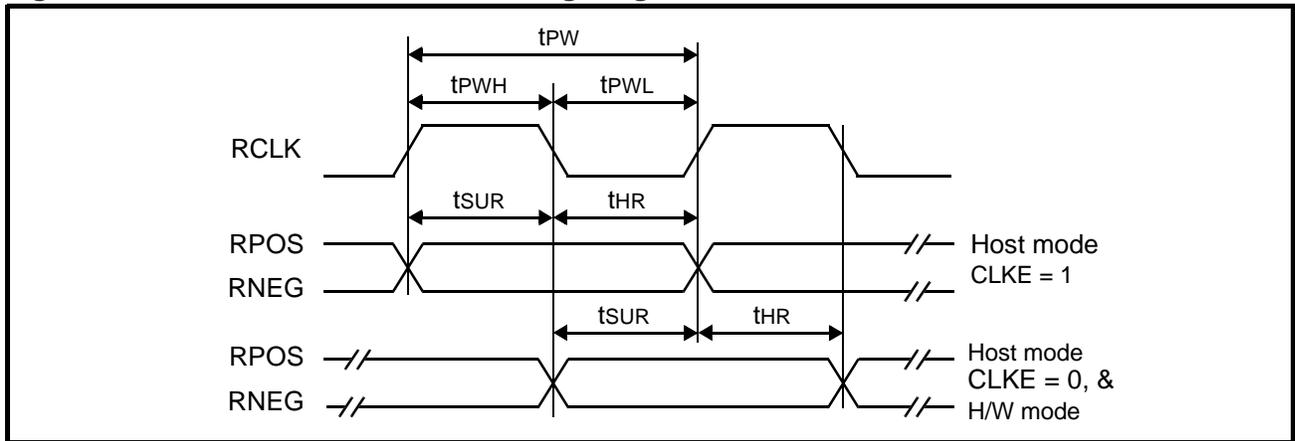

Table 11: LXT301Z Receive Timing Characteristics (See Figure 12)

Parameter		Sym	Min	Typ ¹	Max	Units	Test Conditions
Receive clock duty cycle ²	DSX-1	RCLKd	40	50	60	%	
	E1	RCLKd	40	50	60	%	
Receive clock pulse width ²	DSX-1	tPW	594	648	702	ns	
	E1	tPW	447	488	529	ns	
Receive clock pulse width High	DSX-1	tPWH	–	324	–	ns	
	E1	tPWH	–	244	–	ns	
Receive clock pulse width Low	DSX-1	tPWL	270	324	378	ns	
	E1	tPWL	203	244	285	ns	
RPOS/RNEG to RCLK rising setup time	DSX-1	tSUR	50	270	–	ns	
	E1	tSUR	50	203	–	ns	
RCLK rising to RPOS/RNEG hold time	DSX-1	tHR	50	270	–	ns	
	E1	tHR	50	203	–	ns	

1. Typical values are at 25 °C and are for design aid only; they are not guaranteed and not subject to production testing.
 2. RCLK duty cycle widths will vary depending on extent of received pulse jitter displacement. Max and Min RCLK duty cycles are for worst case jitter conditions (0.4 UI clock displacement for 1.544 MHz, 0.2 UI clock displacement for 2.048 MHz).

Figure 12: LXT301Z Receive Clock Timing Diagram

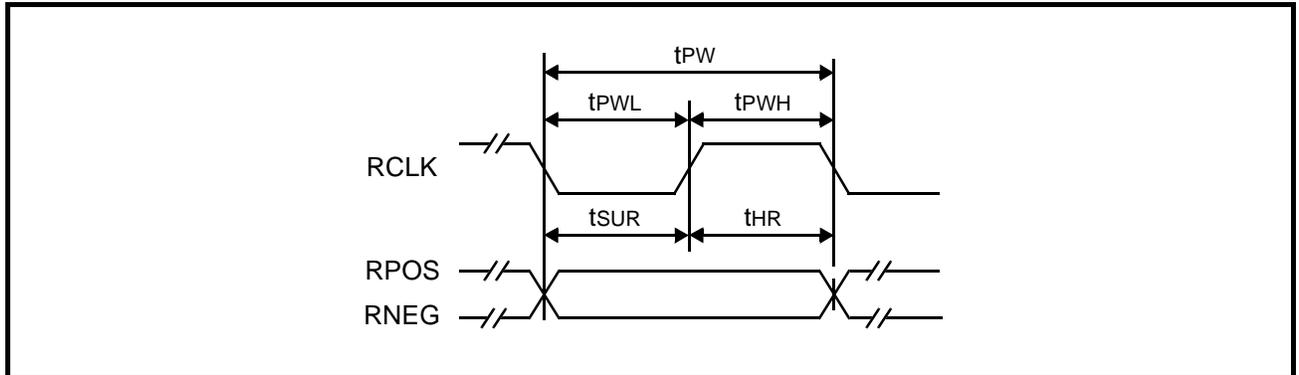

Table 12: LXT300Z/301Z Master Clock and Transmit Timing Characteristics (See Figure 13)

Parameter	Sym	Min	Typ ¹	Max	Units	
Master clock frequency	DSX-1	MCLK	–	1.544	–	MHz
	E1	MCLK	–	2.048	–	MHz
Master clock tolerance	MCLKt	–	±100	–	ppm	
Master clock duty cycle	MCLKd	40	–	60	%	
Crystal frequency (LXT300Z only)	DSX-1	fc	–	6.176	–	MHz
	E1	fc	–	8.192	–	MHz
Transmit clock frequency	DSX-1	TCLK	–	1.544	–	MHz
	E1	TCLK	–	2.048	–	MHz
Transmit clock tolerance	TCLKt	–	±50	–	ppm	
Transmit clock duty cycle	TCLKd	10	–	90	%	
TPOS/TNEG to TCLK setup time	tsUT	25	–	–	ns	
TCLK to TPOS/TNEG hold time	tHT	25	–	–	ns	

1. Typical values are at 25 °C and are for design aid only; they are not guaranteed and not subject to production testing.
 2. Not production tested but guaranteed by design and other correlation methods.

Figure 13: LXT300Z/301Z Transmit Clock Timing Diagram

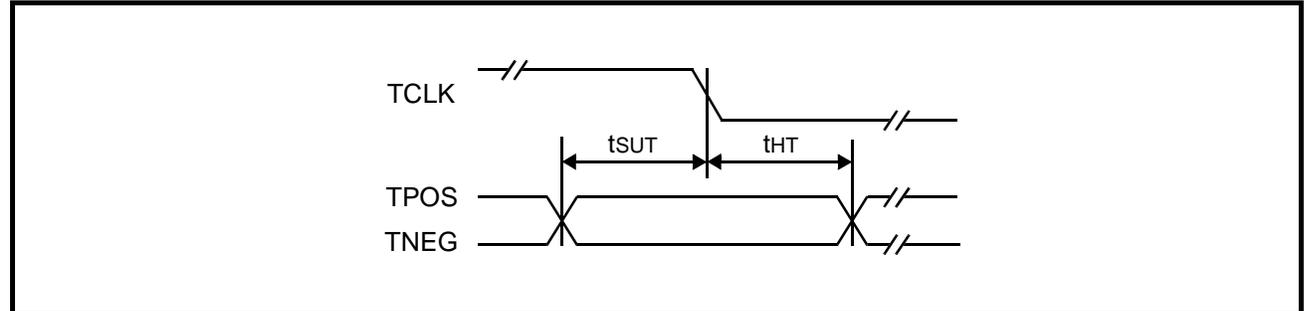

Table 13: LXT300Z Serial I/O Timing Characteristics (See Figures 14 and 15)

Parameter	Sym	Min	Typ ¹	Max	Units	Test Conditions
Rise/fall time - any digital output	t _{RF}	–	–	100	ns	Load 1.6 mA, 50 pF
SDI to SCLK setup time	t _{DC}	50	–	–	ns	
SCLK to SDI hold time	t _{CDH}	50	–	–	ns	
SCLK Low time	t _{CL}	240	–	–	ns	
SCLK High time	t _{CH}	240	–	–	ns	
SCLK rise and fall time	t _R , t _F	–	–	50	ns	
$\overline{\text{CS}}$ to SCLK setup time	t _{CC}	50	–	–	ns	
SCLK to $\overline{\text{CS}}$ hold time	t _{CCH}	50	–	–	ns	
$\overline{\text{CS}}$ inactive time	t _{CWH}	250	–	–	ns	
SCLK to SDO valid	t _{CDV}	–	–	200	ns	
SCLK falling edge or $\overline{\text{CS}}$ rising edge to SDO high Z	t _{CDZ}	–	100	–	ns	

1. Typical values are at 25° C and are for design aid only; they are not guaranteed and not subject to production testing.

Figure 14: LXT300Z Serial Data Input Timing Diagram

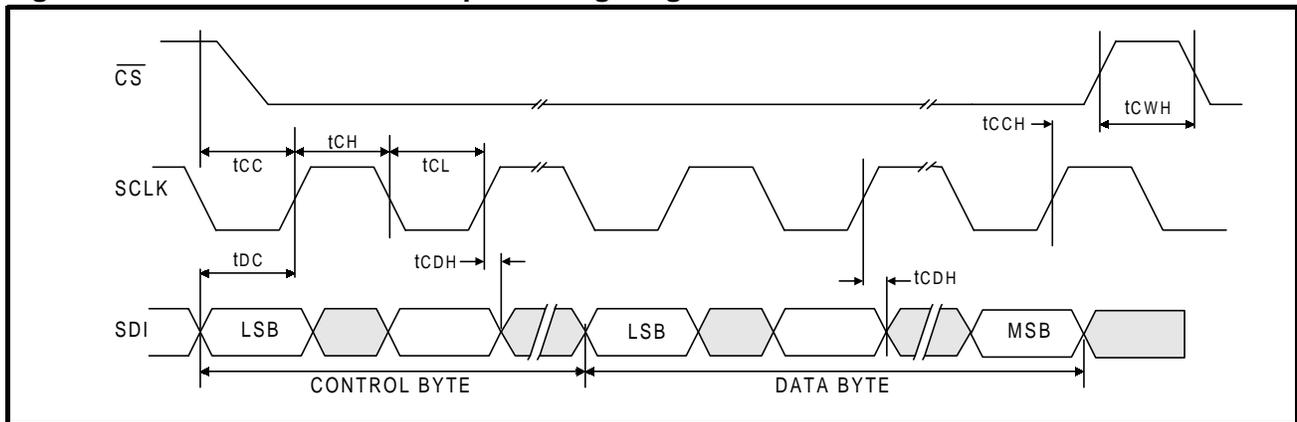
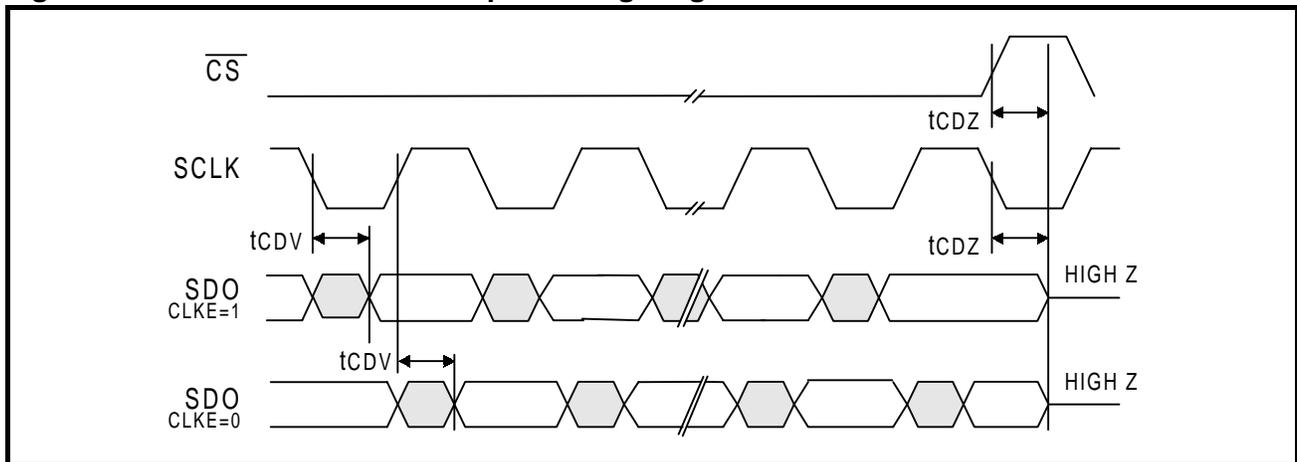

Figure 15: LXT300Z Serial Data Output Timing Diagram



MECHANICAL SPECIFICATIONS

Figure 16: Package Specifications

28-pin Plastic Dual In-Line Package

- Extended Temperature Range (-40 °C to 85 °C)
- Part Number LXT300ZNE
- Part Number LXT301ZNE

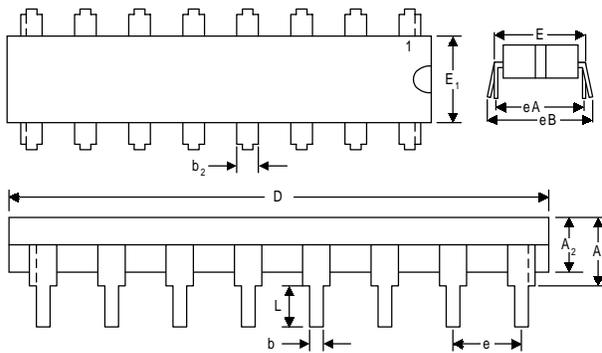

28-pin Plastic Leaded Chip Carrier

- Extended Temperature Range (-40 °C to 85 °C)
- Part Number LXT300ZPE
- Part Number LXT301ZPE

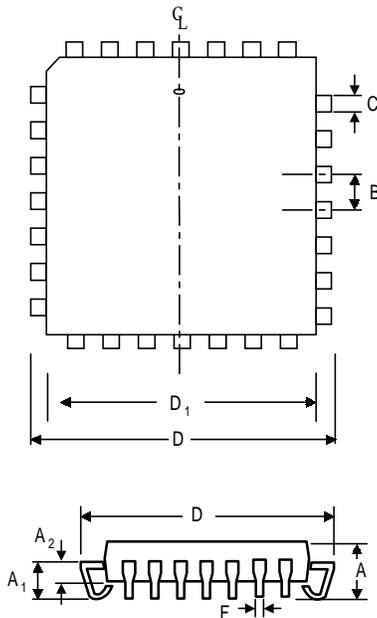

Dim	Inches		Millimeters	
	Min	Max	Min	Max
A	–	0.250	–	6.350
A2	0.125	0.195	3.175	4.953
b	0.014	0.022	0.356	0.559
b2	0.030	0.070	0.762	1.778
D	1.380	1.565	35.052	39.751
E	0.600	0.625	15.240	15.875
E1	0.485	0.580	12.319	14.732
e	0.100 BSC ¹ (nominal)		2.540 BSC ¹ (nominal)	
eA	0.600 BSC ¹ (nominal)		15.240 BSC ¹ (nominal)	
eB	–	0.700	–	17.780
L	0.115	0.200	2.921	5.080

1. BSC—Basic Spacing between Centers.

Dim	Inches		Millimeters	
	Min	Max	Min	Max
A	0.165	0.180	4.191	4.572
A1	0.090	0.120	2.286	3.048
A2	0.062	0.083	1.575	2.108
B	.050 BSC ¹ (nominal)		1.27 BSC ¹ (nominal)	
C	0.026	0.032	0.660	0.813
D	0.485	0.495	12.319	12.573
D1	0.450	0.456	11.430	11.582
F	0.013	0.021	0.330	0.533

1. BSC—Basic Spacing between Centers.

Corporate Headquarters

9750 Goethe Road
Sacramento, California 95827
Telephone: (916) 855-5000
Fax: (916) 854-1101
Web: www.level1.com



The Americas

EAST

Eastern Area Headquarters & Northeastern Regional Office

234 Littleton Road, Unit 1A
Westford, MA 01886
USA
Tel: (978) 692-1193
Fax: (978) 692-1124

North Central Regional Office

One Pierce Place
Suite 500E
Itasca, IL 60143
USA
Tel: (630) 250-6044
Fax: (630) 250-6045

Southeastern Regional Office

4020 WestChase Blvd
Suite 100
Raleigh, NC 27607
USA
Tel: (919) 836-9798
Fax: (919) 836-9818

WEST

Western Area Headquarters

3375 Scott Blvd., #110
Santa Clara, CA 95054
USA
Tel: (408) 496-1950
Fax: (408) 496-1955

South Central Regional Office

2340 E. Trinity Mills Road
Suite 306
Carrollton, TX 75006
USA
Tel: (972) 418-2956
Fax: (972) 418-2985

Southwestern Regional Office

28203 Cabot Road
Suite 300
Laguna Niguel, CA 92677
USA
Tel: (714) 365-5655
Fax: (714) 365-5653

Latin/South America

9750 Goethe Road
Sacramento, CA 95827
USA
Tel: (916) 855-5000
Fax: (916) 854-1102

International

ASIA/PACIFIC

Asia / Pacific Area Headquarters

101 Thomson Road
United Square #08-01
Singapore 307591
Thailand
Tel: +65 353 6722
Fax: +65 353 6711

Central Asia/Pacific Regional Office

Suite 305, 4F-3, No. 75,
Hsin Tai Wu Road
Sec. 1, Hsi-Chih,
Taipei County, Taiwan
Tel: +886 22 698 2525
Fax: +886 22 698 3017

Northern Asia/Pacific Regional Office

Nishi-Shinjuku, Mizuma
Building 8F
3-3-13, Nishi-Shinjuku,
Shinjuku-Ku
Tokyo, 160-0023 Japan
Tel: +81 3 3347-8630
Fax: +81 3 3347-8635

EUROPE

European Area Headquarters

Parc Technopolis-Bat. Zeta 3,
avenue du Canada -
Z.A. de Courtaboeuf
Les Ulis Cedex 91974
France
Tel: +33 1 64 86 2828
Fax: +33 1 60 92 0608

Central and Southern Europe Regional Office

“Regus”
Feringastrasse 6
D-85774 Muenchen-
Unterfoerhring, Germany
Tel: +49 89 99 216 375
Fax: +49 89 99 216 319

Northern Europe Regional Office

Torshamnsgatan 35
164/40 Kista/Stockholm,
Sweden
Tel: +46 8 750 3980
Fax: +46 8 750 3982

<u>Revision</u>	<u>Date</u>	<u>Status</u>
-----------------	-------------	---------------

1.1	03/99	Reformat to new template, added RCLK to Figure 2, and made minor editorial changes.
1.0	11/97	Added LXT301ZPE package.
0.0	04/96	Standard Release.

The products listed in this publication are covered by one or more of the following patents. Additional patents pending.
5,008,637; 5,028,888; 5,057,794; 5,059,924; 5,068,628; 5,077,529; 5,084,866; 5,148,427; 5,153,875; 5,157,690; 5,159,291; 5,162,746; 5,166,635; 5,181,228;
5,204,880; 5,249,183; 5,257,286; 5,267,269; 5,267,746; 5,461,661; 5,493,243; 5,534,863; 5,574,726; 5,581,585; 5,608,341; 5,671,249; 5,666,129; 5,701,099

Copyright © 1999 Level One Communications, Inc., an Intel company. Specifications subject to change without notice.
All rights reserved. Printed in the United States of America.

DS-T300Z/301Z-03/99