

isc Silicon PNP Power Transistor

BDT92F/94F/96F

DESCRIPTION

- DC Current Gain- $h_{FE} = 20 \sim 200 @ I_C = -4A$
- Collector-Emitter Sustaining Voltage-
: $V_{CEO(SUS)} = -60V(\text{Min})$ - BDT92F; $-80V(\text{Min})$ - BDT94F;
 $-100V(\text{Min})$ - BDT96F
- Complement to Type BDT91F/93F/95F

APPLICATIONS

- Designed for use in audio output stages and general amplifier and switching applications.

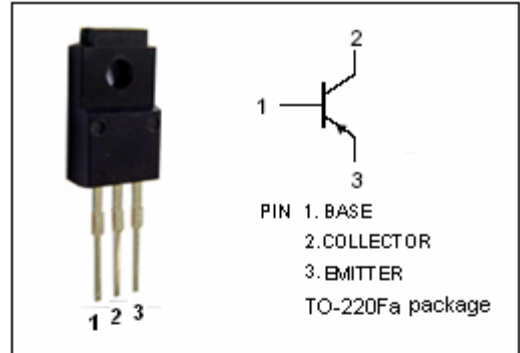

ABSOLUTE MAXIMUM RATINGS($T_a=25^\circ\text{C}$)

SYMBOL	PARAMETER	VALUE	UNIT	
V_{CBO}	Collector-Base Voltage	BDT92F	-60	V
		BDT94F	-80	
		BDT96F	-100	
V_{CEO}	Collector-Emitter Voltage	BDT92F	-60	V
		BDT94F	-80	
		BDT96F	-100	
V_{EBO}	Emitter-Base Voltage	-7	V	
I_C	Collector Current-Continuous	-10	A	
I_{CM}	Collector Current-Peak	-20	A	
I_B	Base Current-Continuous	-4	A	
P_C	Collector Power Dissipation @ $T_C=25^\circ\text{C}$	32	W	
T_J	Junction Temperature	150	$^\circ\text{C}$	
T_{stg}	Storage Temperature Range	-65~150	$^\circ\text{C}$	

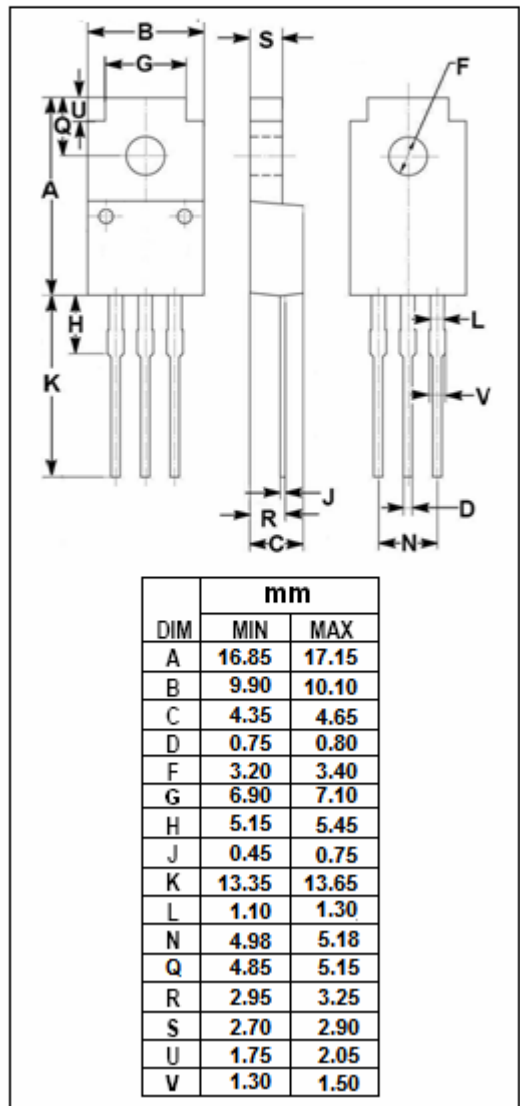

THERMAL CHARACTERISTICS

SYMBOL	PARAMETER	MAX	UNIT
$R_{th\ j-c}$	Thermal Resistance, Junction to Case	6.4	$^\circ\text{C}/\text{W}$

isc Silicon PNP Power Transistor

BDT92F/94F/96F

ELECTRICAL CHARACTERISTICS

 $T_C=25^\circ\text{C}$ unless otherwise specified

SYMBOL	PARAMETER	CONDITIONS	MIN	TYP.	MAX	UNIT	
$V_{CE(SUS)}$	Collector-Emitter Sustaining Voltage	BDT92F	$I_C = -100\text{mA}; I_B = 0$	-60			V
		BDT94F		-80			
		BDT96F		-100			
$V_{CE(sat)-1}$	Collector-Emitter Saturation Voltage	$I_C = -4\text{A}; I_B = -0.4\text{A}$			-1	V	
$V_{CE(sat)-2}$	Collector-Emitter Saturation Voltage	$I_C = -10\text{A}; I_B = -3.3\text{A}$			-3	V	
$V_{BE(on)}$	Base-Emitter On Voltage	$I_C = -4\text{A}; V_{CE} = -4\text{V}$			-1.6	V	
I_{CBO}	Collector Cutoff Current	$V_{CB} = V_{CB0max}; I_E = 0$ $V_{CB} = \frac{1}{2}V_{CB0max}; I_E = 0, T_J = 150^\circ\text{C}$			-0.1 -1	mA	
I_{CEO}	Collector Cutoff Current	$V_{CE} = V_{CE0max} \text{ V}; I_B = 0$			-0.2	mA	
I_{EBO}	Emitter Cutoff Current	$V_{EB} = -7\text{V}; I_C = 0$			-0.1	mA	
h_{FE-1}	DC Current Gain	$I_C = -4\text{A}; V_{CE} = -4\text{V}$	20		200		
h_{FE-2}	DC Current Gain	$I_C = -10\text{A}; V_{CE} = -4\text{V}$	5				
f_T	Current-Gain—Bandwidth Product	$I_C = -500\text{mA}; V_{CE} = -10\text{V}$	4			MHz	

Switching times

t_{on}	Turn-On Time	$I_C = -4\text{A}; I_{B1} = -I_{B2} = -0.4\text{A}$		0.5	1.5	μs
t_{off}	Turn-Off Time			1	3	μs